

3K 3000 Series PRODUCT HIGHLIGHTS



Performance and visibility

The single piece engine cover allows the operator to see objects to the rear that are three feet high, within 3 feet of the machine. This improved rear visibility and the excellent visibility to the drum allow the operator superb machine control in confined spaces. All 3000 Series machines have dual amplitudes/dual frequencies and traction control to match the machine to any compaction need on any terrain. All models are available in either smooth drum or pad foot configurations. The pad foot drum machines can be ordered with an optional strike off blade and the smooth drum machines can be fitted with an optional pad foot shell kit.

3000 SERIES HIGHLIGHTS



Operator's compartment

As soon as you climb onto the HAMM 3000 Series roller, you'll see a big difference between it and any other single drum roller. For one thing, the seat swivels from side to side and rotates giving the operator tremendous visibility and control from either side of the machine. Dual, seat mounted, 5-in-1 control levers allow the operator to use either hand to operate all functions of the machine. A tiltable, automotive type, instrument panel has complete operation and diagnostic lights and gauges to keep the operator informed of all machine functions.

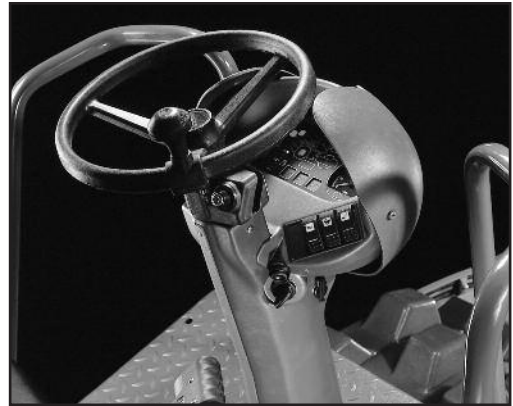

Serviceability

The single piece, clamshell engine cover has hydraulic assist for opening and closing. When open, all daily maintenance and service points are ground level accessible. Fuel tanks are of a size to assure a full day's work without refueling.

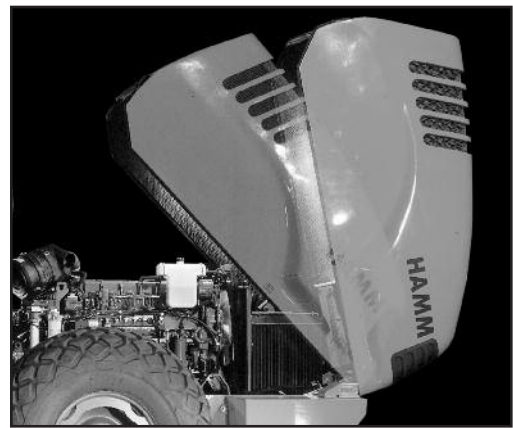

Revolutionary cooling system

The revolutionary cooling system draws cool, clean outside air from just behind the operator's compartment. This air is passed over the hydraulic components and engine and forced through the radiator and oil cooler and out the back of the machine. The exhaust is located at the back so that when mixed with the forced cooling air, exhaust noise and fumes are pushed out the back and away from the machine. The engine cover is also sound insulated for a quieter working environment.

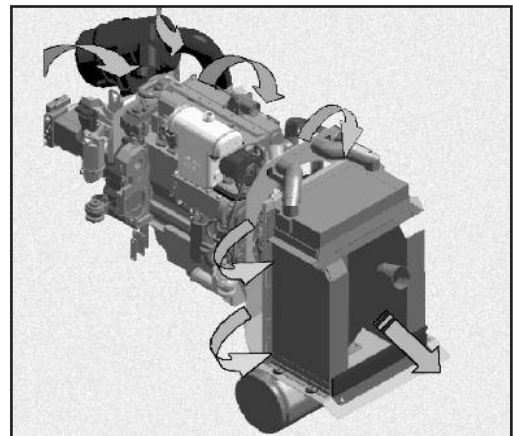

Innovative 3-point articulation joint

The innovative 3-point articulation joint has been designed into all the 3000 Series machines. This 3-point system assures optimum steering stability even during maximum cornering. The drum and rear wheels will maintain contact with the ground through the full 10-degree oscillation even through a full turn. Combine the new articulation joint with traction control and the 3000 Series machines have gradeability that is unmatched in the industry.

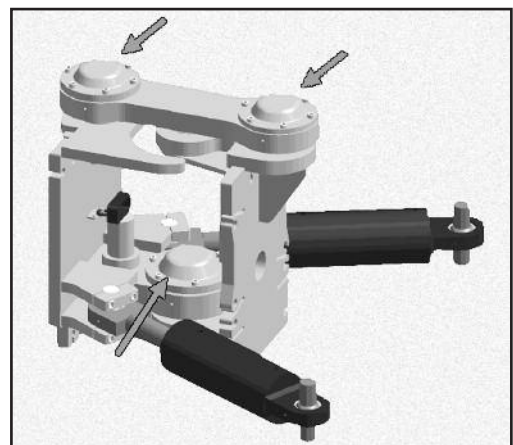

Safety

The 3000 Series of single drum rollers all have a seat mounted emergency stop button located on the operator's left. This button, when depressed, will engage the brakes, stopping the machine; return the drive pump to neutral and stop the engine. There is also a neutral safety start switch that prevents the engine from being started unless the control levers are in neutral and depressed into the brake lock detent. All 3000 Series rollers come standard with ROPS/FOPS, seat belts, back up alarms, handrails for both sides and waffle plating on the floor of the operator's compartment.

WIRTGEN AMERICA - HAMM COMPACTION DIVISION

6030 Dana Way • Antioch, TN 37013 • 615-501-0600 • 615-501-0691 Fax

www.wirtgenamerica.com