

3K 3307 VIO



OSCILLATION



Compactor with vibration and oscillation

- ▶ Ergonomic driver's compartment with unobstructed visibility
- ▶ Simple, automotive style instrumentation
- ▶ Continuous hydrostatic drum and wheel drive
- ▶ High performance, turbo-charged diesel engine that meets all current EPA emission requirements
- ▶ High gradeability through no spin differential and traction control system
- ▶ Unique 3-point articulation joint
- ▶ Hydrostatic steering
- ▶ Easy maintenance and long service intervals

TECHNICAL DATA

3307 VIO

3307 VIO - Compactor with vibration and oscillation

Weights		
Operating weight with ROPS/FOPS	lbs (kg)	13,558 (6150)
Maximum weight	lbs (kg)	17,196 (7800)
Axle load, front/rear	lbs (kg)	7,650/5,908 (3470/2680)
Load per tire, rear	lbs (kg)	2,954 (1340)
Static linear load, front	lbs / in (kg/cm)	115.9 (20,7)
Machine Dimensions		
Max. working width	in (mm)	66.1 (1680)
Turning radius, inside	in (mm)	120 (3060)
Size of tires, rear		AW 14.9-24 8 PR
Diesel engine		
Manufacturer		DEUTZ
Model		TD 2011 L04 W
Number of cylinders		4
Power rat. DIN/ISO3046IFN kW/HP/rpm		68,0/92.5/2600
Power rating SAE J1349, HP/kW/rpm		91.1/68,0/2600
Fuel tank, capacity	Gal (Ltr)	46.2 (175)
Drive		
Hydrostatic drive, front/rear		Hydraulic motor/axle
Speed, work range	mph (km/h)	0-4.2 (0-6,7)
Speed, transport range	mph (km/h)	0-7.8 (0-12,5)
Climbing ability, vibration on/off	%	54/59
Vibration/Oscillation system		
Hydrostatic drive		
Vibration		
Vibration frequency	vpm (Hz)	2,160 (36)
Amplitude	in (mm)	.054 (1,38)
Centrifugal force	lbs (kN)	27,675 (123)
Oscillation		
Oscillation frequency	vpm (Hz)	2,160 (36)
Tangential amplitude	in (mm)	.054 (1,37)
Oscillation force	lbs (kN)	27,675 (123)
Steering		
Steering, type		Pivoted steering
Steering, actuation		hydrostatic, steering wheel
Steering angle +/-	Grad	35°
Oscillation angle +/-	Grad	10°
Brake system		
Service brake, mode of action		hydrostatic
Service brake, actuation		Drive lever
Parking brake, mode of action		Spring-loaded/multi-disc
Parking brake, actuation		Electric and/or automatic
Emergency brake, mode of action		hydr./mech.
Emergency brake, actuation		Emergency stop button
Standard equipment		
Suspended driving platform, access from either side. Sliding and swiveling operator's seat. 2 multifunctional drive levers. Traction control. Tilt steering wheel and instrument panel. Modern information and control display. Sound insulation. Tilttable GFK-engine hood. CE-conformity.		
Optional equipment		
Large capacity and comfortable ROPS cab with panoramic view, work lights, wipers front/rear, exterior and interior mirrors, and heater with dust free ventilation. Air conditioning. Radio. Hamm Compaction meter. Documentation system CDS. Tachometer. Speedometer. Frequency meter. Special paint.		

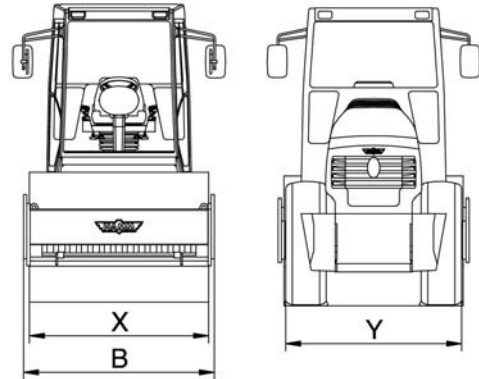
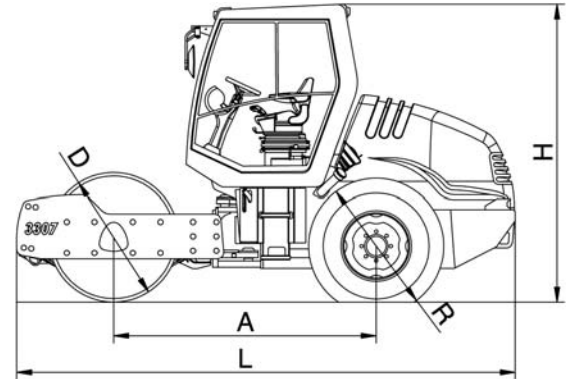

Further data on request / subject to change

WIRTGEN AMERICA - HAMM COMPACTION DIVISION

6030 Dana Way • Antioch, TN 37013 • 615-501-0600 • 615-501-0691 Fax
www.hammcompactors.com

		3307 VIO
Total length	L	184" (4680)
Total width	B	70.5" (1790)
Total height	H	110" (2790)
Wheel base	A	97" (2465)
Drum width	X	66" (1680)
Drum diameter	D	48" (1216)
Width over tires	Y	65" (1650)
Diameter of tires	R	50" (1280)