

HD+ 110 VV / VV HF



(Machine shown with optional equipment)



Articulated tandem roller

- ▶ Ergonomic operator's compartment with access from either the left or right side
- ▶ A full 180° rotating operator's station with swiveling seat and tilt steering wheel
- ▶ Excellent visibility to the drum surfaces, drum edges and work areas
- ▶ 6.7" drum offset to either left or right side
- ▶ Hydrostatic dual drum drive, infinitely variable
- ▶ High performance, turbo-charged diesel engine that meets all current EPA emission requirements
- ▶ Dual pump water system with all spray nozzles clearly visible from the operator's seat
- ▶ Electronic engine management system and adjustable, automatic speed control



HD+ 110 VV / VV HF



TECHNICAL DATA

HD+ 110 VV

HD+ 110 VV HF

Weights

Operating weight with ROPS/FOPS	lbs (kg)	23,215 (10530)	23,215 (10530)
Maximum weight	lbs (kg)	29,321 (13300)	29,321 (13300)
Axle load, front/rear	lbs (kg)	11,718/11,497 (5315/5215)	11,718/11,497 (5315/5215)
Static linear load, front/rear	lbs / in (kg/cm)	178/174 (31,6/31,0)	178/174 (31,6/31,0)

Machine Dimensions

Drum width	in (mm)	66 (1680)	66 (1680)
Max. working width	in (mm)	72.8 (1850)	72.8 (1850)
Turning radius, inside	in (mm)	207 (5250)	207 (5250)

Diesel engine

Manufacturer	DEUTZ	DEUTZ
Model	TCD 2012 L04 2V	TCD 2012 L04 2V
Number of cylinders	4	4
Power rating DIN/ISO30461FN kW/HP/rpm	100,0/136.0/2300	100,0/136.0/2300
Power rating SAE J1349, HP/kW/rpm	134.0/100,0/2300	134.0/100,0/2300
Fuel tank, capacity	Gal (Ltr)	40.0 (150)

Drive

Hydrostatic drive, front/rear	Hydraulic motor/hydraulic motor	Hydraulic motor/hydraulic motor
Speed, range	mph (km/h)	0-6.8 (0-11,0)
Climbing ability, vibration on/off	%	35/40

Vibration system

Hydrostatic drive, Double drum vibration, independently adjustable

Vibration

Vibration frequency, front, low/high	vpm (Hz)	2,400/3,000 (40/50)	2,700/4,020 (45/67)
Vibration frequency, rear, low/high	vpm (Hz)	2,400/3,000 (40/50)	2,700/4,020 (45/67)
Amplitude, front, high/low	in (mm)	.035/.020 (0,89/0,51)	.029/.013 (0,74/0,33)
Amplitude, rear, high/low	in (mm)	.035/.020 (0,89/0,51)	.029/.013 (0,74/0,33)
Centrifugal force, front, high/low	lbs (kN)	30,100/27,400 (134/122)	30,100/28,760 (134/128)
Centrifugal force, rear, high/low	lbs (kN)	30,100/27,400 (134/122)	30,100/28,760 (134/128)

Steering

Steering, type	Pivoted steering	Pivoted steering
Steering, actuation	hydrostatic, steering wheel	hydrostatic, steering wheel
Steering angle +/-	Grad	30°
Oscillation angle +/-	Grad	10°

Brake system

Service brake, mode of action	hydrostatic	hydrostatic
Service brake, actuation	Drive lever	Drive lever
Parking brake, mode of action	Spring-loaded/multi-disc	Spring-loaded/multi-disc
Parking brake, actuation	Electric and/or automatic	Electric and/or automatic
Emergency brake, mode of action	hydr./mech.	hydr./mech.
Emergency brake, actuation	Emergency stop button	Emergency stop button

Sprinkler system

Water sprinkler, type	Pressure	Pressure
Actuation, sprinkling	interval/manual	interval/manual
Water tank, capacity	Gal (Ltr)	220 (834)

Standard equipment

Suspended operator's platform, swiveling and rotating operator's seat, 2 multifunctional levers, left and right at seat, indicators for: engine coolant temperature, working hours, fuel level, hydraulic oil temperature, water level in tanks, speedometer, vibration frequency of each drum, control lights and emergency stop button. 2 work lights, front and rear, turn signals, flashers and drum edge lights. Seat belt, back-up alarm and main battery switch. 6.7" hydraulic offset to either side. Independent amplitude and frequency adjustment for each drum. Adjustable, automatic speed control. Electronic engine management system. Tachometer. 2 mirrors, front mounted. CE-conformity.

Optional equipment

Panoramic ROPS cab with: heater, defroster, dust-free ventilation, interior lighting, front and rear wipers, front and rear work lights and interior mirror. Air conditioning. Radio. Edge pressing and cutting equipment. Special paint. Asphalt temperature gauge. ROPS/FOPS mounted night paving lights, 4 or 6, quartz halogen or Xenon. HCCQ-asphalt compaction meter.

Further data on request / subject to change

HD+ 110 VV - Articulated tandem roller

HD+ 110 VV HF - Articulated tandem roller with high frequency

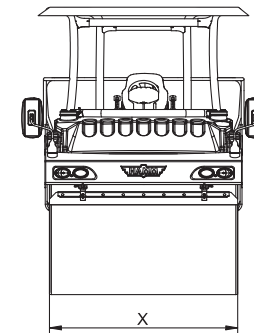
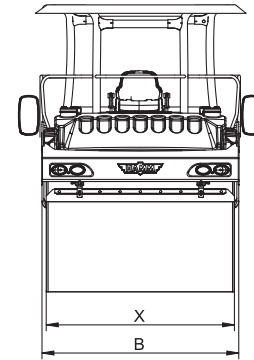
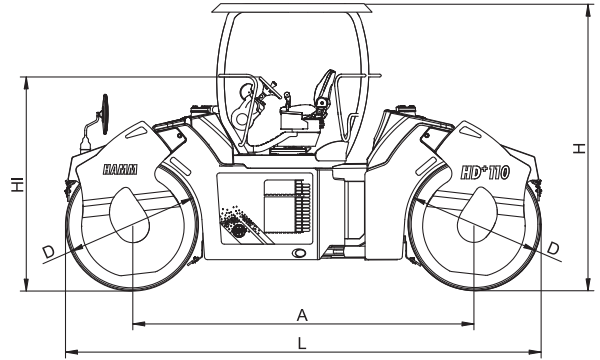

		HD+ 110 VV / VV HF
Total length	L	181" (4600)
Total width	B	70.5" (1790)
Total height	H	122" (3100)
Wheel base	A	133.8" (3400)
Drum width	X	66" (1680)
Drum diameter	D	48" (1200)
High loading min.	HI	86" (2185)

WIRTGEN AMERICA - HAMM COMPACTION DIVISION

6030 Dana Way • Antioch, TN 37013 • 615-501-0600 • 615-501-0691 Fax

www.wirtgenamerica.com