

HD 10 C VV



Articulated tandem roller

- ▶ Hydrostatic dual drum drive
- ▶ Automatic/manual vibration system
- ▶ Hydrostatic articulated steering
- ▶ Excellent maneuverability
- ▶ Low sound level
- ▶ 3 braking systems with Emergency Stop button
- ▶ Plastic water tank, pressurized water system, hand serviceable, plastic spray nozzles
- ▶ Fixed, 2.2" (56mm), offset

TECHNICAL DATA

HD 10 C VV

HD 10 C VV - Articulated tandem roller

Weights

Operating weight with ROPS	lbs (kg)	3,682 (1670)
Maximum weight	lbs (kg)	4,299 (1950)
Axle load, front/rear	lbs (kg)	1,786/1,896 (810/860)
Static linear load, front/rear	lbs / in (kg/cm)	45.3/48.1 (8,1/8,6)

Machine Dimensions

Max. working width	in (mm)	41.5 (1056)
Turning radius, inside	in (mm)	83.9 (2130)

Diesel engine

Manufacturer	KUBOTA	
Model	D1005-E3B	
Number of cylinders	3	
Power rating DIN/ISO30461FN kW/HP/rpm	14,8/20.1/2700	
Power rating SAE J1349, HP/kW/rpm	20.0/14,8/2700	
Fuel tank, capacity	Gal (Ltr)	8.7 (33)

Drive

Hydrostatic drive, front/rear	Hydraulic motor/hydraulic motor	
Speed, infinitely variable	mph (km/h)	0-6.8 (0-11,0)
Climbing ability, vibration on/off	%	30/40

Vibration system

Hydrostatic drive. Front and back vibration / one double switch, automatic vibration switch-off at overspeed.
Manual or automatic vibration control

Vibration

Vibration frequency, front	vpm (Hz)	3,120/3,900 (52/65)
Vibration frequency, rear	vpm (Hz)	3,120/3,900 (52/65)
Amplitude, front	in (mm)	.018/.018 (0,45/0,45)
Amplitude, rear	in (mm)	.018/.018 (0,45/0,45)
Centrifugal force, front	lbs (kN)	3,600/5,625 (16/25)
Centrifugal force, rear	lbs (kN)	3,600/5,625 (16/25)

Steering

Steering, type	Pivoted steering	
Steering, actuation	hydrostatic, steering wheel	
Steering angle +/-	Grad	33°
Oscillation angle +/-	Grad	8°

Brake system

Service brake, mode of action	hydrostatic
Service brake, actuation	Drive lever
Parking brake, mode of action	Spring-loaded/multi-disc
Parking brake, actuation	Electric and/or automatic
Emergency brake, mode of action	hydr./mech.
Emergency brake, actuation	Emergency stop button

Sprinkler system

Water sprinkler, type	Pressure	
Actuation, sprinkling	interval/manual	
Water tank, capacity	Gal (Ltr)	20 (75)

Standard equipment

Comfort seat, multifunctional control lever, hourmeter, pilot lamps and emergency stop button. ROPS, seat belt, back up alarm. Lighting according to German Road Regulation. CE-conformity.

Optional equipment

ROPS mounted, front and rear work lights. Rotating beacon. Special paint.

Further data on request / subject to change

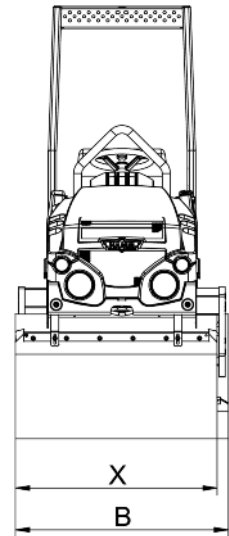
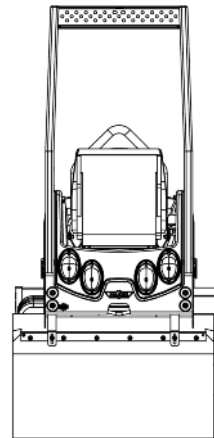
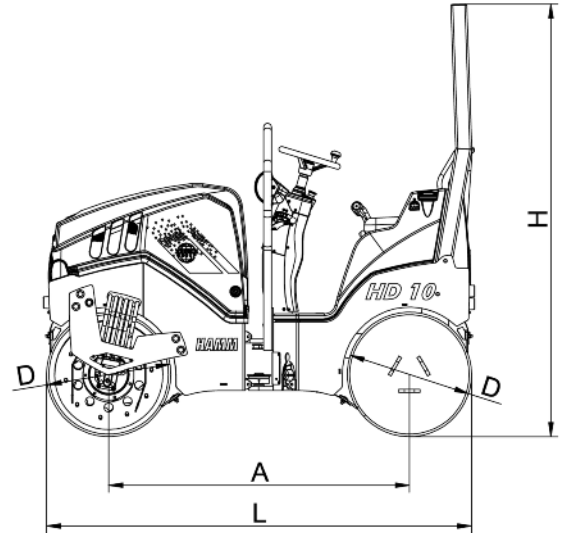

		HD 10 C VV
Total length	L	88.9" (2260)
Total width	B	41.5" (1056)
Total height	H	87" (2210)
Wheel base	A	61.4" (1560)
Drum width	X	39.4" (1000)
Drum diameter	D	24.4" (620)

WIRTGEN AMERICA - HAMM COMPACTION DIVISION

6030 Dana Way • Antioch, TN 37013 • 615-501-0600 • 615-501-0691 Fax
www.wirtgenamerica.com