

HD 10_{VT} / HD 12_{VT}



Articulated combination roller

- ▶ Hydrostatic drum and rear wheel drive
- ▶ Automatic/manual vibration system
- ▶ Hydrostatic articulated steering
- ▶ Excellent maneuverability
- ▶ Low sound level
- ▶ 3 braking systems with Emergency Stop button
- ▶ Plastic water tank, pressurized water system, hand serviceable, plastic spray nozzles for front drum
- ▶ Separate emulsion tank and spray system for rear tires
- ▶ 2" (50mm) offset capability

HD 10 VT / HD 12 VT



TECHNICAL DATA

HD 10 VT

HD 12 VT

Weights			
Operating weight with ROPS	lbs (kg)	5,148 (2335)	5,776 (2620)
Maximum weight	lbs (kg)	6,173 (2800)	6,614 (3000)
Axle load, front/rear	lbs (kg)	2,668/2,480 (1210/1125)	2,965/2,811 (1345/1275)
Load per tire, rear	lbs (kg)	620 (281,3)	703 (318,8)
Static linear load, front	lbs / in (kg/cm)	67.7 (12,1)	56.5 (11,2)
Machine Dimensions			
Drum width	in (mm)	39.4 (1000)	47.2 (1200)
Max. working width	in (mm)	41.4 (1050)	48.0 (1220)
Turning radius, inside	in (mm)	97.2 (2470)	93.3 (2370)
Size of tires, rear		205/60-R15	205/60-R15
Diesel engine			
Manufacturer		KUBOTA	KUBOTA
Model		D1503-M-E3B	D1503-M-E3B
Number of cylinders		3	3
Power rating DIN/ISO30461FN kW/HP/rpm		22,9/31.1/2700	22,9/31.1/2700
Power rating SAE J1349, HP/kW/rpm		30.7/22,9/2700	30.7/22,9/2700
Fuel tank, capacity	Gal (Ltr)	11 (43)	11 (43)
Drive			
Hydrostatic drive, front/rear		Hydraulic motor/hydraulic motor	Hydraulic motor/hydraulic motor
Speed, infinitely variable	mph (km/h)	0-6.8 (0-11,0)	0-6.8 (0-11,0)
Climbing ability, vibration on/off	%	30/40	30/40
Vibration system			
Hydrostatic drive. Front vibration / one switch, automatic vibration switch-off at overspeed. Manual or automatic vibration control			
Vibration			
Vibration frequency, front	vpm (Hz)	3,120/4,020 (52/67)	3,120/4,020 (52/67)
Amplitude, front	in (mm)	.021/.021 (0,54/0,54)	.020/.020 (0,52/0,52)
Centrifugal force, front	lbs (kN)	6,300/10,350 (28/46)	7,200/11,700 (32/52)
Steering			
Steering, type		Pivoted steering	Pivoted steering
Steering, actuation		hydrostatic, steering wheel	hydrostatic, steering wheel
Steering angle +/-	Grad	32°	32°
Oscillation angle +/-	Grad	8°	8°
Brake system			
Service brake, mode of action		hydrostatic	hydrostatic
Service brake, actuation		Drive lever	Drive lever
Parking brake, mode of action		Spring-loaded/multi-disc	Spring-loaded/multi-disc
Parking brake, actuation		Electric and/or automatic	Electric and/or automatic
Emergency brake, mode of action		hydr./mech.	hydr./mech.
Emergency brake, actuation		Emergency stop button	Emergency stop button
Sprinkler system			
Water sprinkler, type		Pressure	Pressure
Actuation, sprinkling		interval/manual	interval/manual
Water tank, capacity	Gal (Ltr)	48 (180)	48 (180)
Additive sprinkling, type		Pressure	Pressure
Actuation, additive sprinkling		Push button	Push button
Additive tank, capacity	Gal (Ltr)	4.8 (18)	4.8 (18)

Standard equipment

2" offset capability, comfort seat, multifunctional control lever, hourmeter, pilot lamps and emergency stop button. ROPS, seat belt, back up alarm. Lighting according to German Road Regulation. CE-conformity.

Optional equipment

ROPS mounted, front and rear work lights. Rotating beacon. Special paint.

Further data on request / subject to change

HD 10 VT - Articulated combination roller
HD 12 VT - Articulated combination roller

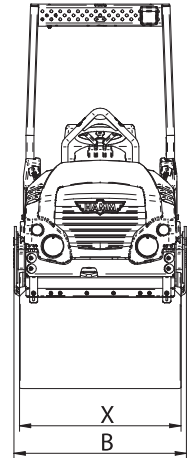
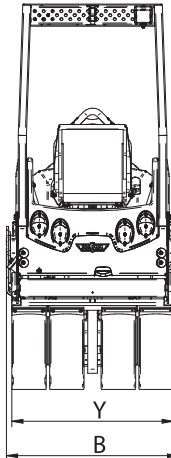
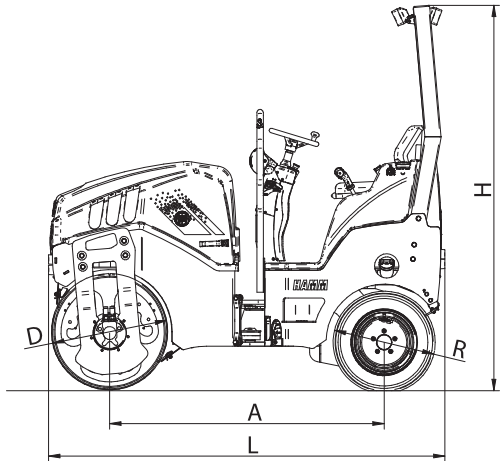

		HD 10 VT	HD 12 VT
Total length	L	96.8" (2460)	96.8" (2460)
Total width	B	43.7" (1110)	51.6" (1310)
Total height	H	94" (2390)	94" (2390)
Wheel base	A	67" (1700)	67" (1700)
Drum width	X	39.4" (1000)	47.2" (1200)
Drum diameter	D	28.3" (720)	28.3" (720)
Width over tires	Y	39.4" (1000)	39.4" (1000)
Diameter of tires	R	24.8" (630)	26.4" (670)

WIRTGEN AMERICA - HAMM COMPACTION DIVISION

6030 Dana Way • Antioch, TN 37013 • 615-501-0600 • 615-501-0691 Fax

www.wirtgenamerica.com