

HD 10 vv



Articulated tandem roller

- ▶ Hydrostatic dual drum drive
- ▶ Automatic/manual vibration system
- ▶ Hydrostatic articulated steering
- ▶ Excellent maneuverability
- ▶ Low sound level
- ▶ 3 braking systems with Emergency Stop button
- ▶ Plastic water tank, pressurized water system, hand serviceable, plastic spray nozzles
- ▶ 2" (50mm) offset capability

TECHNICAL DATA

HD 10 VV

HD 10 VV - Articulated tandem roller

Weights		
Operating weight with ROPS	lbs (kg)	5,467 (2480)
Maximum weight	lbs (kg)	6,173 (2800)
Axle load, front/rear	lbs (kg)	2,667/2,800 (1210/1270)
Static linear load, front/rear	lbs / in (kg/cm)	67.7/71.0 (12,1/12,7)
Machine Dimensions		
Drum width	in (mm)	39.4 (1000)
Max. working width	in (mm)	41.4 (1050)
Turning radius, inside	in (mm)	97.2 (2470)
Diesel engine		
Manufacturer	KUBOTA	
Model	D1503-M-E3B	
Number of cylinders	3	
Power rating DIN/ISO30461FN kW/HP/rpm	22,9/31.1/2700	
Power rating SAE J1349, HP/kW/rpm	30.7/22,9/2700	
Fuel tank, capacity	Gal (Ltr)	11 (42)
Drive		
Hydrostatic drive, front/rear	Hydraulic motor/hydraulic motor	
Speed, infinitely variable	mph (km/h)	0-6.8 (0-11,0)
Climbing ability, vibration on/off	%	30/40
Vibration system		
Hydrostatic drive. Front and back vibration / one double switch, automatic vibration switch-off at overspeed. Manual or automatic vibration control		
Vibration		
Vibration frequency, front	vpm (Hz)	3,120/4,020 (52/67)
Vibration frequency, rear	vpm (Hz)	3,120/4,020 (52/67)
Amplitude, front	in (mm)	.021/.021 (0,54/0,54)
Amplitude, rear	in (mm)	.021/.021 (0,54/0,54)
Centrifugal force, front	lbs (kN)	6,300/10,350 (28/46)
Centrifugal force, rear	lbs (kN)	6,300/10,350 (28/46)
Steering		
Steering, type	Pivoted steering	
Steering, actuation	hydrostatic, steering wheel	
Steering angle +/-	Grad	32°
Oscillation angle +/-	Grad	8°
Brake system		
Service brake, mode of action	hydrostatic	
Service brake, actuation	Drive lever	
Parking brake, mode of action	Spring-loaded/multi-disc	
Parking brake, actuation	Electric and/or automatic	
Emergency brake, mode of action	hydr./mech.	
Emergency brake, actuation	Emergency stop button	
Sprinkler system		
Water sprinkler, type	Pressure	
Actuation, sprinkling	interval/manual	
Water tank, capacity	Gal (Ltr)	48 (180)
Standard equipment		
2" offset capability, comfort seat, multifunctional control lever, hourmeter, pilot lamps and emergency stop button. ROPS, seat belt, back up alarm. Lighting according to German Road Regulation. CE-conformity.		
Optional equipment		
ROPS mounted, front and rear work lights. Rotating beacon. Special paint.		

Further data on request / subject to change

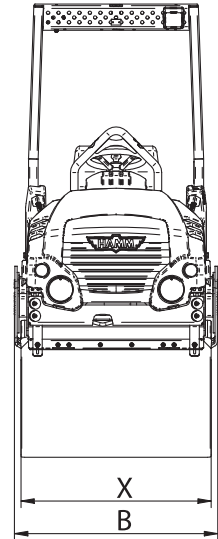
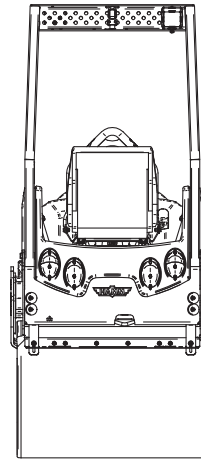
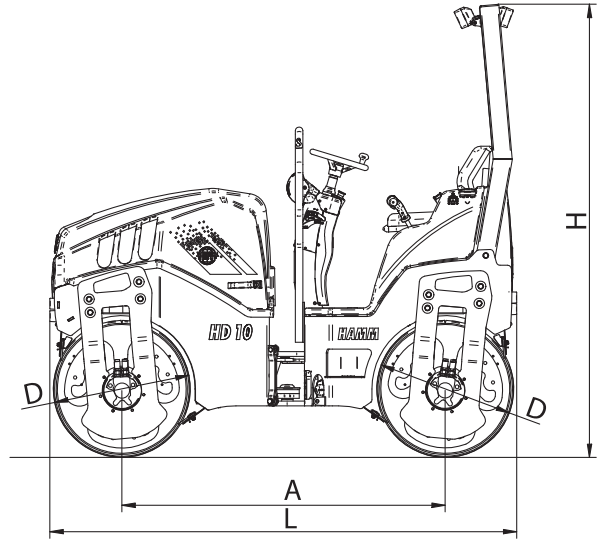

		HD 10 VV
Total length	L	96.8" (2460)
Total width	B	43.7" (1110)
Total height	H	94" (2390)
Wheel base	A	67" (1700)
Drum width	X	39.4" (1000)
Drum diameter	D	28.3" (720)

WIRTGEN AMERICA - HAMM COMPACTION DIVISION

6030 Dana Way • Antioch, TN 37013 • 615-501-0600 • 615-501-0691 Fax
www.wirtgenamerica.com