

HW 90B 10 / 12



Static three-wheel roller

- ▶ Dual operator seats and controls
- ▶ Hydrostatic traction drive
- ▶ 2 weight classes: 10-12 t, able to handle 12-14 t
- ▶ Ideal load distribution between front and rear drums
- ▶ Pressured sprinkler system with interval switch
- ▶ Larger water tank with 105 gallons capacity
- ▶ 4-cylinder turbo-charged diesel engine
- ▶ Split front drum

TECHNICAL DATA

HW 90B/10

HW 90B/12

Weights

Operating weight	lbs (kg)	23,567 (10690)	27,524 (12485)
Maximum weight	lbs (kg)	30,864 (14000)	35,273 (16000)
Axle load, front/rear	lbs (kg)	9,017/14,550 (4090/6600)	11,276/16,248 (5115/7370)
Static linear load, front/rear	lbs / in (kg/cm)	208.2/303.1 (37,2/53,9)	260.4/338.5 (46,5/60,2)

Machine Dimensions

Max. working width	in (mm)	79.5 (2020)	79.5 (2020)
Turning radius, inside	in (mm)	93.1 (2365)	93.1 (2365)

Diesel engine

Manufacturer		DEUTZ	DEUTZ
Model		BF4L 2011	BF4L 2011
Number of cylinders		4	4
Power rating DIN/ISO3046FN kW/HP/rpm		53,5/72.8/2500	53,5/72.8/2500
Power rating SAE J1349, HP/kW/rpm		71.7/53,5/2500	71.7/53,5/2500
Fuel tank, capacity	Gal (Ltr)	37 (140)	37 (140)

Drive

Hydrostatic drive, front/rear		Planetary gear	Planetary gear
Speed, infinitely variable	mph (km/h)	0-6.3 (0-10,2)	0-6.3 (0-10,2)
Climbing ability, with no ballast	%	25/40	25/40

Steering

Steering, type		Pivot steering, front	Pivot steering, front
Steering, actuation		hydrostatic, steering wheel	hydrostatic, steering wheel
Steering angle +/-	Grad	40°	40°
Oscillation angle +/-	Grad	8°	8°

Brake system

Service brake, mode of action		hydrostatic	hydrostatic
Service brake, actuation		Drive lever	Drive lever
Parking brake, mode of action		Spring-loaded/mechanical	Spring-loaded/mechanical
Parking brake, actuation		Electric and/or automatic	Electric and/or automatic
Emergency brake, mode of action		hydr./mech.	hydr./mech.
Emergency brake, actuation		Emergency stop button	Emergency stop button

Sprinkler system

Water sprinkler, type		Pressure	Pressure
Actuation, sprinkling		interval/manual	interval/manual
Water tank, capacity	Gal (Ltr)	105 (400)	105 (400)

Standard equipment

Spring suspended driving position. 2 comfort seats. 2 drive levers. Neutral start switch. Instrument panel with all necessary control instruments including hour meter. Lights. ROPS. CE-conformity.

Optional equipment

Fully enclosed ROPS cab, wipers front and rear, inside mirror, electric fan, sun shades. Heating, beacon, sound insulation, edge pressing and cutting equipment, hydraulic differential lock. Special paint.

Further data on request / subject to change

HW 90B/10 - Static three wheel roller 10t
HW 90B/12 - Static three wheel roller 12t

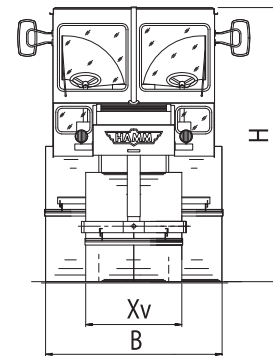
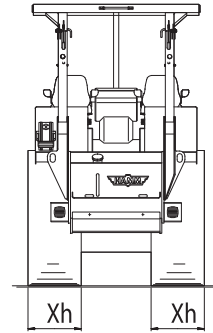
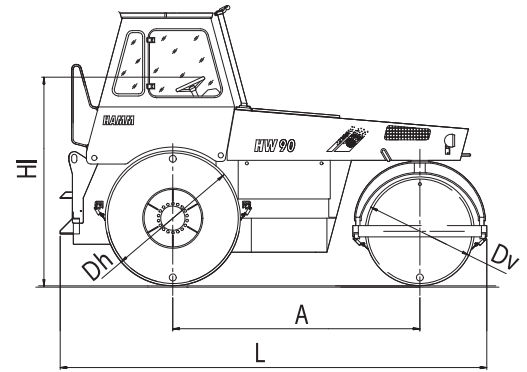

		HW 90B/10	HW 90B/12
Total length	L	192.5" (4890)	192.5" (4890)
Working width	B	79.5" (2020)	79.5" (2020)
Total height	H	126.8" (3220)	126.8" (3220)
Wheel base	A	111.4" (2830)	111.4" (2830)
Drum width, front	Xv	43.3" (1100)	43.3" (1100)
Drum diameter, front	Dv	49.2" (1250)	49.2" (1250)
Drum width, rear	Xh	24.0" (610)	24.0" (610)
Drum diameter, rear	Dh	61.0" (1550)	61.0" (1550)
Height, steering wheel	HI	94.5" (2400)	94.5" (2400)