



MOBIREX

■ TRACK-MOUNTED IMPACT CRUSHERS



Professional uses in natural stone and recycling industry.

For the past 150 years, Kleemann has been developing and manufacturing machines and plants for the natural stone and recycling industry.

One of the most important elements of the Kleemann product range is the track-mounted impact crusher from the MOBIREX series.

MOBIREX impactors are used for soft to medium-hard natural stone, and to recycle construction waste.

In order to offer our customers with more than mainstream plants, Kleemann designed mobile impact crushers, which can do a lot more than just pure volume reduction. The focus today is on cost, the environment, availability, versatility and, above all, the quality of the end product. Simply crushing material is an easy process;

crushing material so that the grain size, grain distribution and cleanliness also meet the high standards for concrete and asphalt requires something more:

- > effective primary screening,
- > intelligent control for optimal loading,
- > adjustable crusher with high drive output and
- > a screening unit with oversize return feed, which does justice to the performance of the crusher.

Kleemann unites these characteristics in its MOBIREX plants, supplementing them with a variety of useful details to create a machine which really sets the standard when it comes to operating efficiency and reliability.



In order to offer its customers more than mainstream plants, Kleemann designed mobile impact crushers, which can do a lot more than just pure volume reduction.

Simply crushing material is an easy process; crushing material so that the grain size, grain distribution and cleanliness also meet the high standards for concrete and asphalt requires something more.



Contents overview

> Page 04 **Machine features**

> Page 06 **Configuration**

CONTRACTOR LINE

> Page 08 **MR 110 EVO**

> Page 10 **MR 130 EVO**

QUARRY LINE

> Page 12 **MR 122**

> Page 14 **MR 150**

> Page 16 **MR 170**

> Page 18 **Crushing curves**

Your advantages at a glance.

» 1 Feeding unit

- > Continuous flow of material to the crusher through a variable speed control feeder
- > Hydraulic folding hopper walls
- > High wear resistance

» 2 Primary screening 2.2 Integrated grizzly

- > Compact dimensions
- > Suitable for recycling plants and applications with a low fines level
- > Low weight
- > Flexible, thanks to its varied features

» 2 Primary screening 2.1 Double-deck heavy-duty screen

- > Effective primary screening of fines and contaminated material
- > Top deck interchangeable punched sheet or grizzly, bottom deck wire mesh or rubber blank
- > Discharge material can be conveyed either to the left or to the right
- > Improves flow of material to crusher reducing blockages and feed surges
- > Faster screen mesh replacement thanks to good accessibility

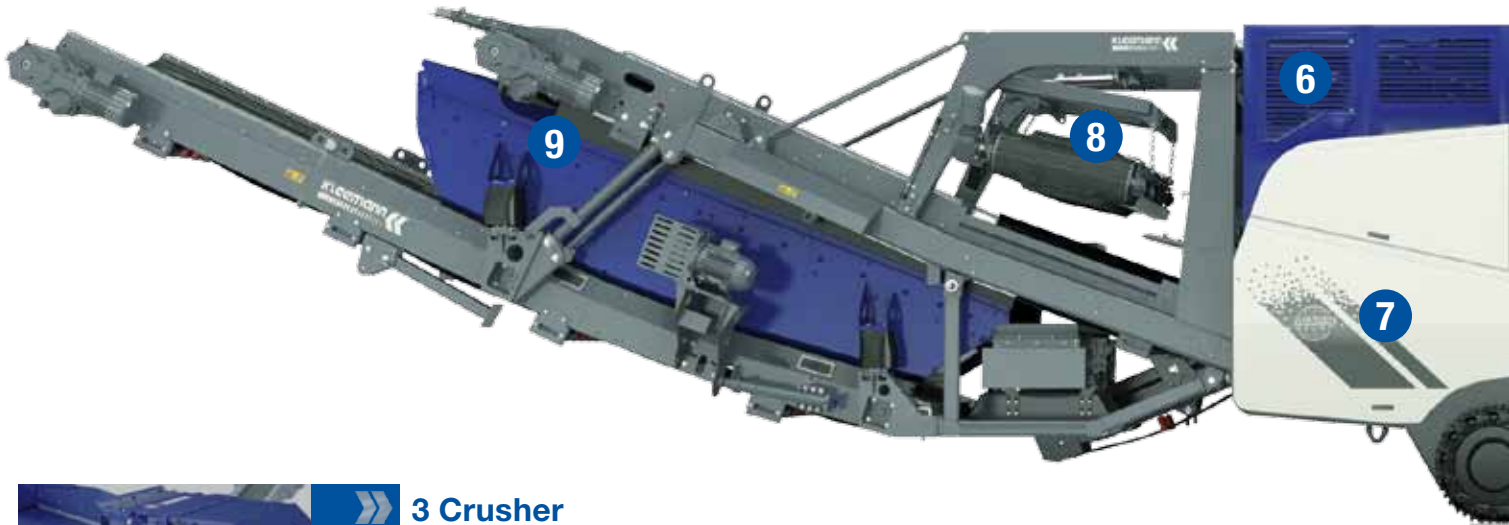

» 3 Crusher



- > Two-stage crushing for optimal grain reduction
- > Large range of possible end grain sizes and grain curves
- > Fully hydraulic crusher adjustment with effective overload protection (Contractor Line)
- > Gap setting down to the exact millimeter at the touch of a button (Contractor Line)
- > Perfect material flow and reduced wear thanks to free flow material transfer at crusher inlet and outlet and crusher bypass
- > Excellent crushing effect due to improved baffle-plate technology

» 4 Vibrating discharge chute

- > Reduced wear due to enlarged expansion room under the crusher
- > Maximum conveying capacity also for cohesive material
- > Even distribution of crushing material on a wide discharge conveyor, which results in increased efficiency at steel discharge
- > Safer process due to large ground clearance

» 5 Chassis

- > Outstanding accessibility for maintenance and cleaning
- > Sturdy steel structure with fully welded I-beam chassis
- > High-quality running gear components
- > Even weight distribution for optimal maneuverability on impassable terrain

» 6 Power supply unit

- > Intercooled diesel engine with direct fuel injection and turbocharger
- > High-performance generator for the drive of all electric components (feeder trough, grizzly, return conveyor, vibrating discharge chute, classifying screen)

» 7 Electrical system

- > Effective guard against dust and moisture through double protective housing, vibration isolation and over pressure system
- > Simple and logical control of all functions via touch panel (Contractor Line)
- > Simple error diagnostics by text indicator
- > Remote maintenance system

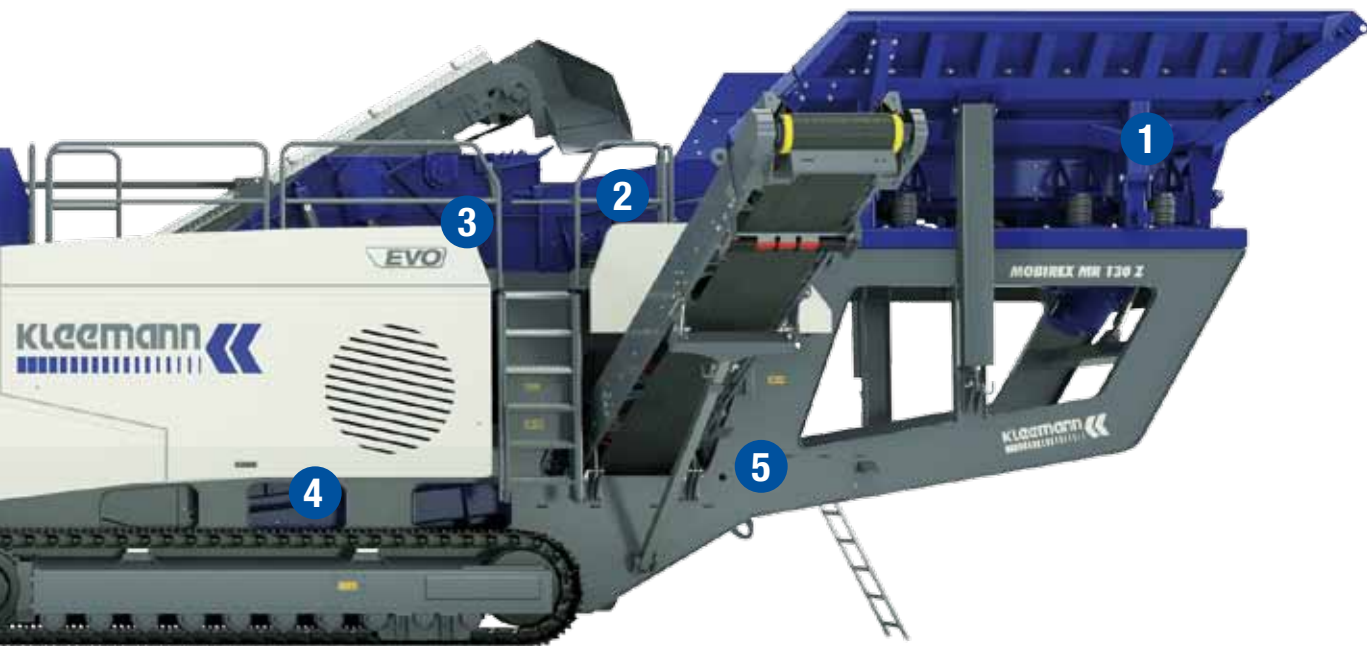

» 8 Magnetic separator (optional)

- > High-performance electro- or permanent magnet with maximum discharge capacity
- > Hydraulic lifting / lowering function (Contractor Line) by means of radio remote control

» 9 Screening unit (optional)

CONTRACTOR LINE

- > Single-deck vibrating screen with large screening surface
- > Can be hydraulically lowered for maintenance work
- > Drive using geared motor
- > Generously dimensioned bearing
- > Option to operate in closed or open loop



Technical details for your overall performance.

MOBIREX COMPONENTS / INDIVIDUAL PLANT CONFIGURATION

- | | |
|---------------------|---------------------------------|
| 1 Feeding unit | 5 Chassis |
| 2 Primary screening | 6 Power supply unit |
| 3 Crusher | 7 Electrical system |
| 4 Discharge chute | 8 Magnetic separator (optional) |
| | 9 Screening unit (optional) |

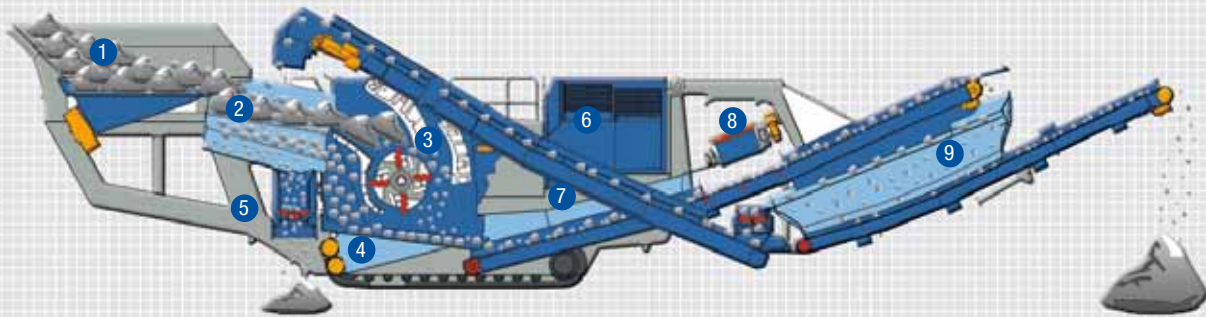

1 Feeding unit

- > Solid hopper made of wear-resistant steel
- > Hopper walls can be folded hydraulically
- > Can be mechanically or hydraulically locked from the ground
- > Feeder trough with integrated slotted grizzly or subsequent double-deck pre-screen
- > Variable speed via frequency controlled electric motors

2 Primary screening

2.1 Independent pre screen

- > Double-deck heavy-duty screen
- > Upper deck either slotted grizzly or punched sheet
- > Lower deck either rubber blank or wire cloth
- > Possible process variations:
 - a. All feed material into the crusher
 - b. Coarse grain into the crusher, fine grain by-passed
 - c. Coarse grain into the crusher, medium grain by-passed, fine grain to stockpile
 - d. Coarse grain into the crusher, medium-fine grain to stockpile
- > Frequency of drive regulated by angular gear (Contractor Line)

2.2 Integrated slotted grizzly

- > Feeder trough with integrated slotted grizzly
- > Upper deck: either slotted grizzly or punched sheet
- > Lower deck: either rubber blank or wire cloth
- > Variable speed via frequency controlled electric motors

3 Crusher

- > SHB series in robust design
- > Two full hydraulically adjustable impact toggles
- > Bolted wear plates of high-strength steel
- > Generously dimensioned rotor bearings

CONTRACTOR LINE

- > Wedge clamping system for C-form-rotor ledges for quick and efficient replacement
- > Wear-resistant manganese crusher inlet with cast iron cover with triple-deck rubber curtain and tough chains, can be lifted hydraulically using radio remote control
- > Mechanical direction of rotor rotation with rotor fuse
- > Fully hydraulic gap setting with automatic detection of zero point and target value setting
- > Speed control for rotor
- > Hydraulic overload protection

4 Vibrating discharge chute

- > Efficient drive thanks to vibration motors
- > Large trough design
- > Bolted wear lining

5 Chassis

- > Straight-forward design
- > Sturdy steel structure with fully welded I-beam chassis
- > High-quality running gear components

6 Power supply unit

- > Intercooled diesel engine with direct fuel injection and turbocharger
- > High-performance generator for the drive of all electric components (feeder trough, grizzly, return conveyor, vibrating discharge chute, final screen)

CONTRACTOR LINE

- > Diesel-electric direct drive
- > Power transmission to the crusher by means of turbo fluid coupling and v-belt
- > Separate drive system via electric motor and tandem pump

QUARRY LINE

- > Diesel-electric drive
- > Electric crusher drive
- > Drive system via crusher drive motor using electromagnetic coupling

7 Electrical system

- > PLC control
- > Vibration-isolated switch cabinet mounting
- > Double switch cabinet protective housing with over pressure system
- > Built-in remote maintenance system via GSM modem

CONTRACTOR LINE

- > Touchscreen with menu guide and visualization
- > Text indicator display
- > Operation of all crushing functions from the screen

QUARRY LINE

- > Display with fault codes

8 Magnetic separator (optional)

- > High-performance electro- or permanent magnet
- > Magnet can be lifted or lowered via remote control (Contractor line)
- > Generously dimensioned stainless steel discharge chute

9 Screening unit (optional for MR 110 and MR 130)

- > Single-deck vibrating screen with large screening surface
- > Can be hydraulically lowered for maintenance work
- > Oversize return feed; side discharge also possible
- > Drive using geared motor
- > Transmission of power by means of articulated shaft
- > Generously dimensioned bearing



Optional for MR 110 and MR 130: Screening unit for producing defined end grain sizes.

CONTRACTOR LINE

The Contractor Line plants are designed in such a way that they can adapt to almost all working conditions – with regard to both the feed material and movement of the machinery.

They are comparatively easy to transport and have drive concepts that accommodate changing operational conditions. That means they are more than equipped for the most varied of applications, as well as for work in recycling and natural stone.

QUARRY LINE

The Quarry Line plants have been especially developed for the hard conditions experienced in quarries.

Their diesel-electric drive concept is extremely efficient and facilitates the operation of the plants via an external power source. Furthermore, this system allows for a reliable electrical locking device with interlinked plant combinations.



CONTRACTOR LINE

MR 110 EVO

The new generation of mobile impact crushers from Kleemann are universally adaptable plants which are suited for processing both blasted natural stone, asphalt and demolition waste as well as producing a first-class end quality product. Despite its comparatively “small” crusher inlet widths of 44" (1,100 mm or 52" (1,300 mm) (MR 110 EVO / MR 130 EVO), they achieve outputs that up to now were only known to be achievable with larger crushing plants.

This quantum leap is owed not only to the two completely newly developed crushers with several technical innovations, but mainly to the new material flow concept, which is operated consistently through the entire plant. At the same time, the plants remain relatively easy to transport thanks to their compact dimensions and weight and are ideal for the most diverse applications.

EVO stands for a genuine new development of all plant components, for real progress in terms of performance, economy and wear.

EVO



The two plants are available with an optional screening unit, the oversize can be returned back to the crusher or stockpile to the side. The screening unit is easy to install and remove and has increased in size by 44% in comparison to the previous plant.



Separating made easy:

Even in recycling the separation and sorting of reinforcing steel is an important part of the crushing process. The large ground clearance below the crusher significantly reduces the danger of bridging. In addition, an efficient

magnetic separator is available as an option, which can be hydraulically lowered and lifted using the radio remote control. This way reinforcing steel can be removed quickly and simply and the machine is ready again for operation.

MR 110 R EVO		MR 110 Z EVO	TECHNICAL INFORMATION
Feed size: up to max.	36" x 24" (900 x 600 mm)	Feed size: up to max.	36" x 24" (900 x 600 mm)
Crusher inlet opening:	44" x 32" (1,120 x 800 mm)	Crusher inlet opening:	44" x 32" (1,120 x 800 mm)
Feed capacity*:	up to 350 t/h	Feed capacity*:	up to 350 t/h
Measurements:		Measurements:	
Length: (without screening unit)	53' (16,140 mm)	Length: (without screening unit)	55' 7" (16,940 mm)
Length: (with screening unit)	64' 5" (19,600 mm)	Length: (with screening unit)	67' (20,420 mm)
Width:	9' 10" (3,000 mm)	Width:	9' 10" (3,000 mm)
Feed height:	12' 8" (3,850 mm)	Feed height:	13' 8" (4,165 mm)
Weight: (without final screen)	97,000 lbs (44,000 kg)	Weight: (without final screen)	97,000 lbs (44,000 kg)
Weight: (with final screen)	112,440 lbs (51,000 kg)	Weight: (with final screen)	112,440 lbs (51,000 kg)
<p>All information given is based on a standard design in operating position; subject to technical changes.</p> <p>* depending on the type and consistency of the feed material, the primary screen selected, as well as the end product to be manufactured</p>			



CONTRACTOR LINE

MR 130 EVO

The MR 130 is similar in design to the MR 110. Due to its larger crusher width and more powerful drive, the overall output has once again been considerably increased. Like the MR 110, the MR 130 can also be used for both primary and secondary crushing. The two plants are operated by an intelligent control that works in the background, which optimizes performance and availability.

The operating concept was also adapted to the new design. All main components are displayed on a new touchscreen and all important functions can be started simply and quickly using a well-arranged menu guide.

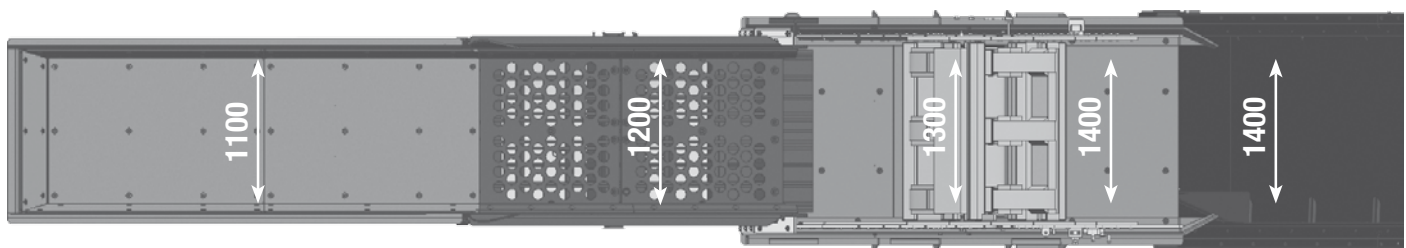
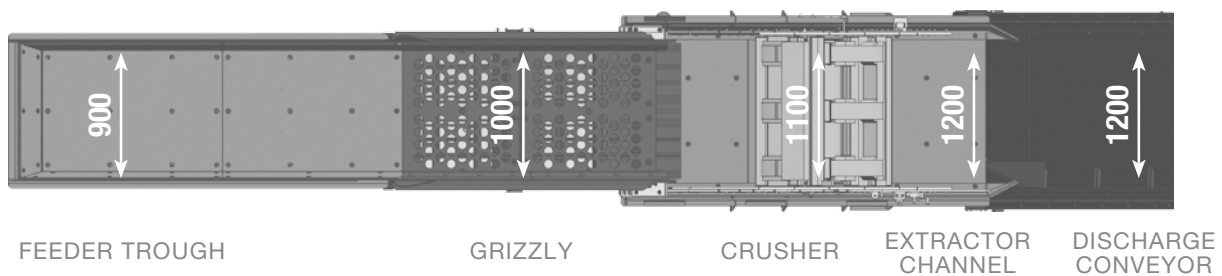

Thanks to an even wider internal space in the crusher and the access below the crusher, material bridging is a thing of the past. Large material flows can be optimally spread out without having to adjust the conveyor speed. The reduced friction on all

components has the result of reduced wear in spite of the increased output. The increased widths, in comparison to the MR 110, allows for a significant increase in output for the MR 130, approximately 30% compared to the smaller plant.

With crushing widths of 44" and 52" (1,100 and 1,300 mm) these two mobile crusher plants are the pioneers of a new generation in the MOBIREX series.



We screen.

Effective primary screening: With the basic model of the MR 130 EVO, primary screening takes place via a slotted integrated grizzly in the feeder trough. The plant is also available with an independent double-deck pre screen

as an option, which is extremely effective at screening fines or simply by-passing material that does not need to be crushed to increase production and reduce wear.

MR 130 R EVO		MR 130 Z EVO		TECHNICAL INFORMATION	
Feed size: up to max.	44" x 28" (1,100 x 700 mm)	Feed size: up to max.	44" x 28" (1,100 x 700 mm)		
Crusher inlet opening:	52" x 36" (1,300 x 900 mm)	Crusher inlet opening:	52" x 36" (1,300 x 900 mm)		
Feed capacity*:	up to 450 t/h	Feed capacity*:	up to 450 t/h		
Measurements:		Measurements:			
Length: (without screening unit)	55' 4" (16,850 mm)	Length: (without screening unit)	58' 9" (17,900 mm)		
Length: (with screening unit)	66' 10" (20,400 mm)	Length: (with screening unit)	70' 3" (21,400 mm)		
Width:	9' 10" (3,000 mm)	Width:	9' 10" (3,000 mm)		
Feed height:	12' 11" (3,920 mm)	Feed height:	14' 2" (4,330 mm)		
Weight: (without final screen)	111,300 lbs (50,500 kg)	Weight: (without final screen)	111,300 lbs (50,500 kg)		
Weight: (with final screen)	129,000 lbs (58,500 kg)	Weight: (with final screen)	129,000 lbs (58,500 kg)		
<p>All information given is based on a standard design in operating position; subject to technical changes.</p> <p>* depending on the type and consistency of the feed material, the primary screen selected, as well as the end product to be manufactured</p>					



QUARRY LINE

MOBIREX MR 122

The classic model among the mobile impact crushers is the MR 122 Z. It is subject to continuous development and equipped with more and more power making the professionals in the recycling and quarry industries really appreciate the uncompromising design of this plant.

The large rotating 52" (1300 mm) rotor is set in motion using a 335 hp (250 kW) electric motor. Even tough reinforced concrete and large limestone blocks are no match for the SHB 12/100 crusher. To meet its purpose, the MOBIREX MR 122 Z has a large free space between the rotor and the vibrating feeder below the crusher. The 55" (1,400 mm) wide main discharge conveyor also transports steel rebar unhindered to the catchment area of the magnet.

A 475 hp (354 kW) diesel engine stimulates the 65-ton MOBIREX. The generator, which is flange-mounted on the flywheel, produces the required electric power for the 335 hp (250 kW) electric motor, which drives the crusher.

The high level of efficiency of this drive variant keeps fuel consumption below 9.25 gal/h (35 l/h) depending on the application.



The MR 122 crushes material with stainless steel.

The clearly structured design of the plant in its basic version is equipped with everything that it needs. An active independent double-deck pre screen with slotted grate or punched sheet, a crusher with two impact aprons, and a vibrating feeder below the crusher, all come as standard with the MOBIREX MR 122 Z.



High-output.

Thanks to a generously dimensioned generator, there is the possibility of powering an additional screening unit.



Cleaning included:

For use with very dirty natural stone, Kleemann designed the MR 122 with a wobbler grizzly for primary screening. In place of the active independent double-deck pre screen, in this special plant there is a two-stage wobbler grizzly,

which is fed directly and cleans the material. In addition to cleaning the feed material, the wobbler grizzly also prevents material sticking to the feeding unit with its self-clean function.

MR 122 Z

TECHNICAL INFORMATION

Feed size: up to max.	48" x 32" (1,200 x 800 mm)
Crusher inlet opening:	50" x 40" (1,270 x 1,000 mm)
Feed capacity*:	up to 450 t/h
Measurements:	
Length:	58' 5" (17,800 mm)
Width:	9' 10" (3,000 mm)
Feed height:	15' 5" (4,700 mm)
Weight: approx.	143,300 (65,000 kg)

All information given is based on a standard design in operating position; subject to technical changes.

* depending on the type and consistency of the feed material, the primary screen selected, as well as the end product to be manufactured



Ideally suited for quarries: diesel-electric drive concept.



QUARRY LINE

MOBIREX MR 150

The largest mobile impact crusher from the range of Kleemann products that can be transported without disassembly is the MR 150 Z. With a 75 ton transport weight, it can be found everywhere that maximum output counts.

In its proven classic design, the MOBIREX MR 150 Z distinguishes itself from the MR 122 Z essentially through its drive concept. Taking advantage of the limited space with a power pack of maximum power, Kleemann has equipped the MOBIREX MR 150 Z with an advanced direct drive.

A 4.2 gallon (16-liter) diesel engine of the latest generation, with a power output of 600 hp (447 kW), uses approximately 469 hp (350 kW) of this for the drive of the heavy-duty SHB 15/100 crusher. The remaining power is used to power the active double-deck pre screen, the vibrating feeder, the belt conveyors and all other drives.

Taking advantage of the limited space with a power pack of maximum power, Kleemann has equipped the MOBIREX MR 150 Z with an advanced direct drive.



The rotor itself weighs nearly 7 tons. In addition, there are four rotor ledges, each weighing 882 lbs (400 kg). Once in use, the rotor tackles everything that comes through its 60" x 40" (1,520 x 1,000 mm) inlet opening. With this drive variant the MR 150 Z is undoubtedly the most economical impact crusher of its kind. Depending on its use, the fuel consumption level ranges from 9 to 12 gallons per hour (35 and 45 l/h).



Efficiency through primary screening:

Emulating the design of its smaller brother MR 122 Z, the plant is equipped with everything that is important for large recycling companies and quarries:

Effective primary screening with a large heavy-duty pre screen, a robust crusher with two impact aprons, a vibrating feeder below the crusher and optional magnet.

MR 150 Z

TECHNICAL INFORMATION

Feed size: up to max.	55" x 32" (1,400 x 800 mm)
Crusher inlet opening: up to max.	60" x 40" (1,520 x 1,000 mm)
Feed capacity*:	up to 550 t/h
Measurements:	
Length:	59' 9" (18,200 mm)
Width:	11' 2" (3,400 mm)
Feed height:	15' 1" (4,600 mm)
Weight: approx.	165,300 lbs (75,000 kg)

All information given is based on a standard design in operating position; subject to technical changes.

* depending on the type and consistency of the feed material, the primary screen selected, as well as the end product to be manufactured



The powerful electromagnet (optional) reliably sorts the reinforced steel.



QUARRY LINE

MOBIREX MR 170

As the classic quarry machine, the MR 170 is optimally adapted to the needs of its user.

Primarily used for limestone, the plant is suitable both as a classic primary crusher with feed sizes of up to 59" (1,500 mm) or in the case of reduced feed size, for crushing final product sizes.

With the electric 476 hp (355 kW) crusher drive, the robust SHH 17/100 impact crusher

with its primary crusher features does not stall, even when processing maximum feed sizes.

Equipped with smaller inlet dimensions, the SHB 17/100 can also achieve smaller end product sizes, for example 0 - 2.2" (0 - 56 mm). With this configuration the plant is very well suited to recycling.

Always powered up.

If a stationary power connection is available in the quarry, this can be used for the MR 170 drive. There is the possibility of installing the plant with a diesel generator, which can be switched off using a selector switch when the stationary power supply is in use.



Primarily used for limestone, the plant is suitable both as a classic primary crusher with feed sizes of up to 59" (1,500 mm) or in the case of reduced feed sizes, for final product sizes.



Constant loading of the impact crusher:

Another important aspect when processing limestone is the effectiveness of the primary screen. With its massive double-deck heavy-duty screening unit, which is 11' 6" (3.5 m) in length, the MR 170 guarantees perfect primary screening and at the same time ensures constant loading

of the impact crusher through leveling of the feed material. Despite the heavy weight of the plant, it can be easily relocated in the quarry. For road transport, the MR 170 is disassembled in two main components.

MR 170 Z

TECHNICAL INFORMATION

Feed size: up to max.	59" x 32" (1,500 x 800 mm)
Crusher inlet opening:	65" x 40" (1,660 x 1,010 mm)
Feed capacity*:	up to 700 t/h
Measurements:	
Length:	64' (19,500 mm)
Width:	11' 2" (3,400 mm)
Feed height:	16' 3" (4,950 mm)
Weight: approx.	209,400 lbs (95,000 kg)

All information given is based on a standard design in operating position; subject to technical changes.

* depending on the type and consistency of the charged material, the primary screen selected, as well as the end product to be manufactured



The enormous 11' 6" (3.5 m) long active double-deck pre screen also works extremely well for very large feed quantities.



We stand for optimal results.

The ideally coordinated components of a plant (feeder trough, pre screen, impact crusher, extractor channel and screening unit), as well as the abilities of the operator, together lead to optimal results.

The crushing curves displayed on the graph provide information about the range of grain sizes achievable, which includes the target grain size. All curves have been created with the results from mobile impact crushers from the MOBIREX series.

The physical characteristics which influence this curve are explained as follows:

Charged material

» Feed size

The maximum feed size should not exceed 80% of the given inlet opening of the crusher.

» Crushing strength

We recommend using the SHB crusher for mineral materials with a maximum crushing strength of up to 150 N/mm².

The SHH crusher, which is available optionally as a primary crusher on the MOBIREX MR 170, is suitable for materials with a maximum crushing strength of up to 100 N/mm²

» Type of mineral

Impact crushers in the SHB series process soft to medium-hard natural stone such as limestone, clay, dolomite and sandstone, as well as construction waste such as rubble, bricks, asphalt and reinforced concrete. Impact crushers in the SHH series are mainly suited for soft natural stone, for example limestone.

Reduction ratio

The maximum reduction ratio (ratio of feed grain size / grain output) largely depends on the physical properties of the feed material. The following are guidelines: limestone, rubble and asphalt up to approximately 15:1; reinforced concrete 10:1 up to 15:1, depending on the concrete and steel content. In the case of particularly soft or brittle material (limestone, rubble, bricks, concrete of a lesser quality), or in the case of closed-circuit production (with a screen and oversize return feed), the reduction ratio can be 20:1 and higher.

Rotor speed and crushing gap

If the rotor speed increases, the crushing curve moves to the "left," which signifies an increase in the proportion of fines in the end product. With the use of an additional grinding path (optional), the proportion of fines increases further. In this case, the feed size must be limited to 10" (250 mm). The MOBIREX is used here solely as a secondary crusher. The principle applies that an increase in the rotor speed and/or a reduction of the crushing gap leads to increased wear and a reduction of the crushing capacity.



Limestone

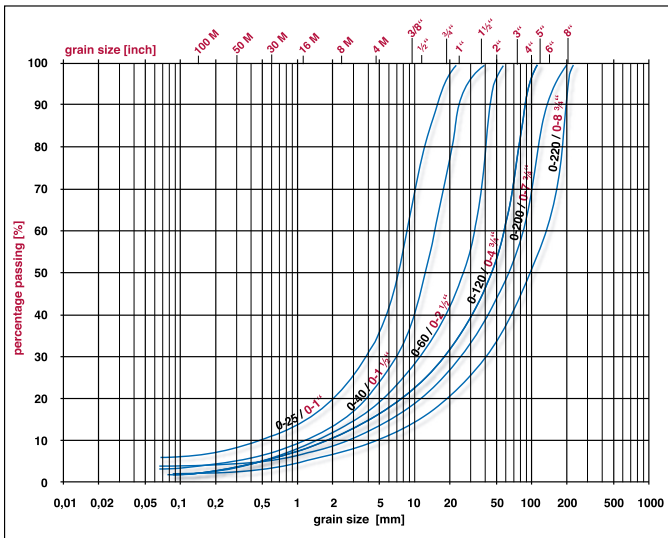

Rubble

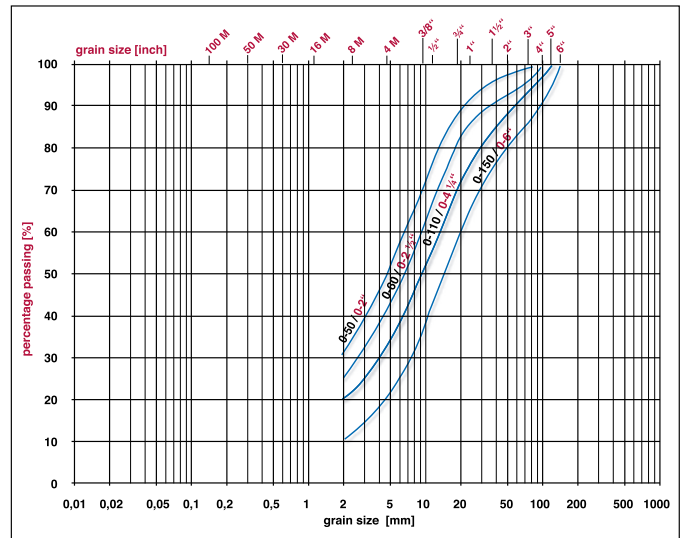

Asphalt

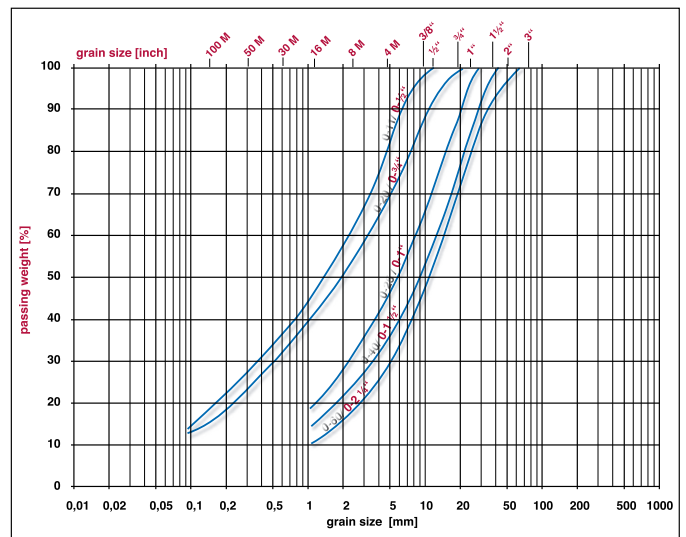



WIRTGEN AMERICA

Kleemann

6030 Dana Way
Antioch, TN 37013 USA

Phone: (615) 501-0602

Fax: (615) 501-0692

E-Mail: kleemann@wirtgenamerica.com

www.wirtgenamerica.com