



CONTRACTOR LINE

MOBISCREEN MS 16 Z

TECHNICAL SPECIFICATIONS

■ TRACK-MOUNTED SCREENING PLANT

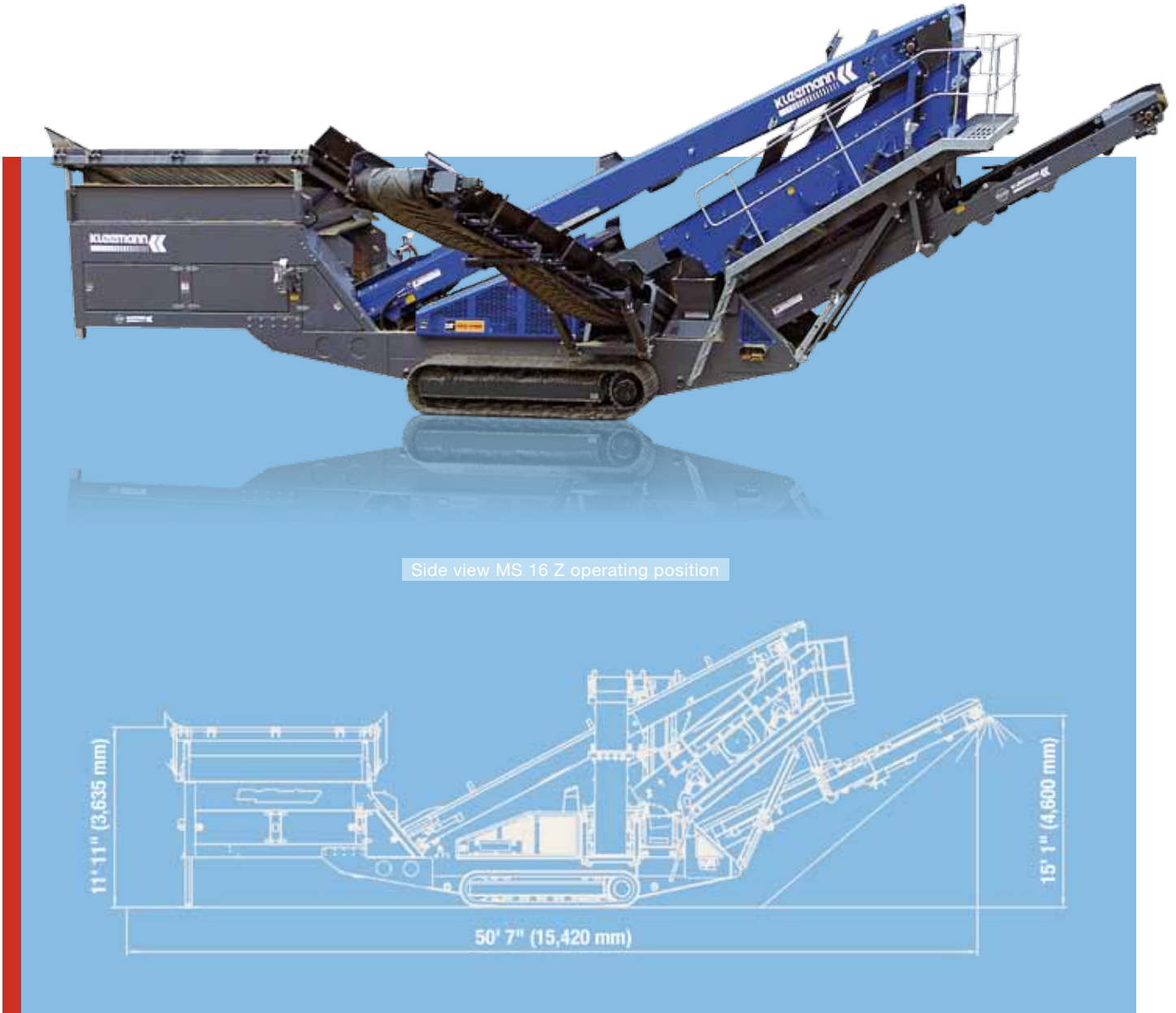

Side view MS 16 Z operating position

TECHNICAL SPECIFICATIONS MS 16 Z

Feeding hopper	
Feed capacity up to approx.	350 t/h
Feed size max.	6" x 6" (150 x 150 mm)
Feed height	11' 11" (3,635 mm)
Hopper capacity	10.5 yd ³ (8 m ³)
Variable speed feed conveyor	
Width x length	4' x 11' 6" (1,200 x 3,500 mm)
Discharge height approx.	–
Feeding belt conveyor screen	
Width x length	3' 5" x 31' 6" (1,050 x 9,600 mm)
Discharge height approx.	–
Screening unit	
Type	double-deck vibration screen
Width x length	5' x 14' (1,520 x 4,270 mm)
Bottom deck underflow discharge conveyor	
Width x length	4' x 20' 8" (1,200 x 6,300 mm)
Discharge height approx.	12' 10" (3,900 mm)

Bottom deck overflow discharge conveyor	
Width x length	2' 2" x 29' 10" (650 x 9,100 mm)
Discharge height approx.	15' 1" (4,600 mm)
Top deck overflow discharge conveyor	
Width x length	2' 2" x 29' 10" (650 x 9,100 mm)
Discharge height approx.	15' 1" (4,600 mm)
Crawler chassis	
Type	D3
Diesel-hydraulic drive	
Engine power	100 hp (75 kW)
Transport	
Transport height approx.	11' 2" (3,400 mm)
Transport length approx.	50' 7" (15,420 mm)
Transport width approx.	9' 10" (3,000 mm)
Transport weight approx.	59,500 lbs (27,000 kg)