



QUARRY LINE

MOBISCREEN MS 20 D

TECHNICAL SPECIFICATIONS

■ TRACK-MOUNTED SCREENING PLANT



Side view MS 20 D operating position

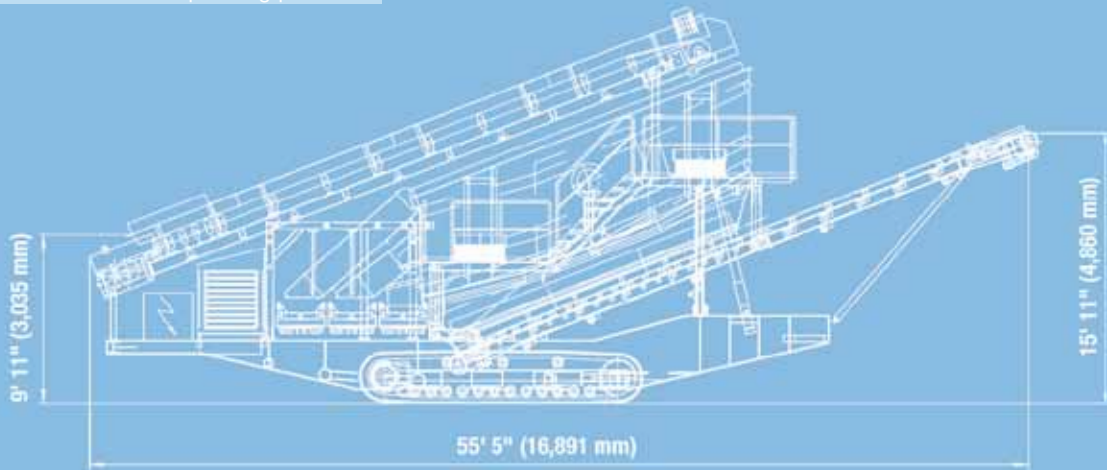

TECHNICAL SPECIFICATIONS MS 20 D

Feeding hopper	
Feed capacity up to approx.	650 t/h
Feed size max.	6" x 6" (150 x 150 mm)
Feed height	9' 11" (3,035 mm)
Hopper capacity	–
Variable speed feed conveyor	
Width x length	4' 7" x 36' 1" (1,400 x 11,000 mm)
Discharge height approx.	–
Screening unit	
Type	triple-deck vibration screen
Width x length	6' 9" x 19' 8" (2,050 x 6,000 mm)
Bottom deck underflow discharge conveyor	
Width x length	4' x 36' 1" (1,200 x 11,000 mm)
Discharge height approx.	15' 11" (4,860 mm)
Bottom deck overflow discharge conveyor	
Width x length	2' 2" x 24' 7" (650 x 7,500 mm)
Discharge height approx.	10' 6" (3,200 mm)
Middle deck overflow discharge conveyor	
Width x length	2' 2" x 24' 7" (650 x 7,500 mm)
Discharge height approx.	10' 6" (3,200 mm)

Transfer discharge conveyor (over size)	
Width x length	2' 2" x 9' 10" (650 x 3,000 mm)
Discharge height approx.	–
Top deck overflow discharge conveyor	
Width x length	2' 2" x 24' 7" (650 x 7,500 mm)
Discharge height approx.	10' (3,040 mm)
Crawler chassis	
Type	D6
Diesel-electric drive	
Engine power	302 hp (225 kW)
Generator	188 hp (175 kVA)
Weight	
Operating weight approx.	88,100 lbs (40,000 kg)
Transport	
Transported in several sections	

6030 Dana Way, Antioch, TN 37013 USA
 Phone: (615) 501-0602 • Fax: (615) 501-0692
www.wirtgenamerica.com

© Klemmann M10024911_A Subject to alteration without prior notice