



QUARRY LINE

# MOBISCREEN MS 23 D

TECHNICAL SPECIFICATIONS

■ TRACK-MOUNTED SCREENING PLANT



Side view MS 23 D operating position

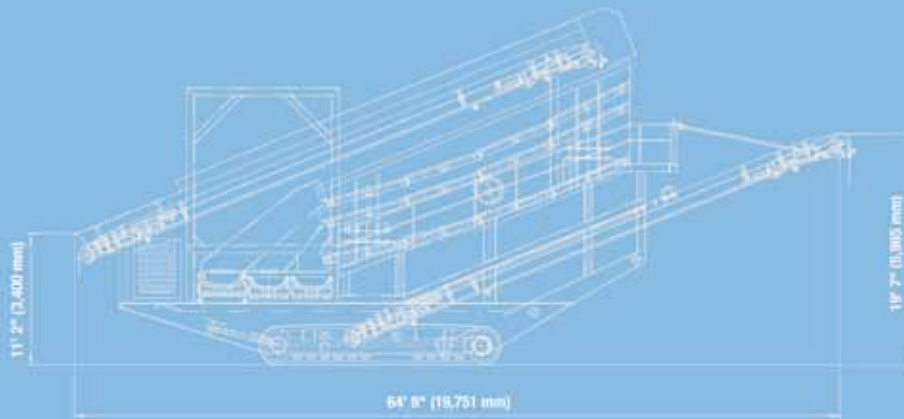

TECHNICAL SPECIFICATIONS MS 23 D

<b>Feeding hopper</b>	
Feed capacity up to approx.	800 t/h
Feed size max.	8" x 8" (200 x 200 mm)
Feed height	11' 2" (3,400 mm)
Hopper capacity	-
<b>Variable speed feed conveyor</b>	
Width x length	6' x 46' (1,800 x 14,000 mm)
Discharge height approx.	-
<b>Screening unit</b>	
Type	triple-deck vibration screen
Width x length	7' 7" x 26' 3" (2,300 x 8,000 mm)
<b>Bottom deck underflow discharge conveyor</b>	
Width x length	6' x 46' (1,800 x 14,000 mm)
Discharge height approx.	19' 7" (5,965 mm)
<b>Transfer belt conveyor screen overflow (lower deck)</b>	
Width x length	2' 8" x 12' 6" (800 x 3,800 mm)
Discharge height approx.	-
<b>Bottom deck overflow discharge conveyor</b>	
Width x length	2' 8" x 32' 10" (800 x 10,000 mm)
Discharge height approx.	14' 5" (4,390 mm)
<b>Transfer belt conveyor screen overflow (middle deck)</b>	
Width x length	2' 8" x 12' 6" (800 x 3,800 mm)

<b>Middle deck overflow discharge conveyor</b>	
Width x length	2' 8" x 32' 10" (800 x 10,000 mm)
Discharge height approx.	14' 5" (4,390 mm)
<b>Transfer discharge conveyor (over size)</b>	
Width x length	3' 4" x 12' 6" (1,000 x 3,800 mm)
<b>Top deck overflow discharge conveyor</b>	
Width x length	3' 4" x 32' 10" (1,000 x 10,000 mm)
Discharge height approx.	14' 5" (4,390 mm)
<b>Crawler chassis</b>	
Type	D7
<b>Diesel-electric drive</b>	
Engine power	302 hp (225 kW)
Generator	268 hp (250 kVA)
<b>Weight</b>	
Operating weight approx.	187,300 lbs (85,000 kg)
<b>Transport</b>	
Transported in several sections	



WIRTGEN AMERICA

6030 Dana Way, Antioch, TN 37013 USA  
 Phone: (615) 501-0602 • Fax: (615) 501-0692  
 www.wirtgenamerica.com