



***Cold milling machines
1300–2000 DC range***

Technical specifications

Technical specification

	2000 DC	1900 DC	1500 DC	1300 DC
Milling width max.	6'7" 2,010 mm	6'3" 1,905 mm	5' 1,500 mm	4'4" 1,320 mm
Milling depth	0-12" 0-300 mm	0-12" 0-300 mm	0-12" 0-300 mm	0-12" 0-300 mm
Milling drum				
Spacing	5/8" 15 mm	5/8" 15 mm	5/8" 15 mm	5/8" 15 mm
Number of tools	162	162	128	115
Drum diameter with tools	39" 980 mm	39" 980 mm	39" 980 mm	39" 980 mm
Drum inclination max.	5 °	5 °	5 °	5 °
Engine				
Make	Mercedes-Benz	Mercedes-Benz	Mercedes-Benz	Mercedes-Benz
Type	OM 442 LA	OM 442 LA	OM 442 LA	OM 442 LA
Cooling	Water	Water	Water	Water
No. of cylinders	8	8	8	8
Output	297 kW/398 HP/404 PS	297 kW/398 HP/404 PS	297 kW/398 HP/404 PS	297 kW/398 HP/404 PS
Engine speed	2,100 rpm	2,100 rpm	2,100 rpm	2,100 rpm
Displacement	892 in. ³ 14,620 cm ³	892 in. ³ 14,620 cm ³	892 in. ³ 14,620 cm ³	892 in. ³ 14,620 cm ³
Fuel consumption: 1/1 load	19 gal/h 73 l/h	19 gal/h 73 l/h	19 gal/h 73 l/h	19 gal/h 73 l/h
Fuel consumption: 2/3 load	16 gal/h 60 l/h	16 gal/h 60 l/h	16 gal/h 60 l/h	16 gal/h 60 l/h
Speed / Gradeability				
Operating speed	0-102 ft/min 0-31 m/min	0-102 ft/min 0-31 m/min	0-102 ft/min 0-31 m/min	0-102 ft/min 0-31 m/min
Travel speed	0-2.80 MPH 0-4.5 km/h	0-2.80 MPH 0-4.5 km/h	0-2.80 MPH 0-4.5 km/h	0-2.80 MPH 0-4.5 km/h
Theor. Gradeability (operating gear)	80 %	80 %	80 %	80 %
Theor. Gradeability (travel gear)	80 %	80 %	80 %	80 %
Ground clearance	9" 235 mm	9" 235 mm	9" 235 mm	9" 235 mm
Weights / Loads				
Front axle load	29,431 lbs 13,350 daN (kg)	29,320 lbs 13,300 daN (kg)	28,659 lbs 13,000 daN (kg)	28,439 lbs 12,900 daN (kg)
Rear axle load	21,494 lbs 9,750 daN (kg)	21,384 lbs 9,700 daN (kg)	20,722 lbs 9,400 daN (kg)	20,502 lbs 9,300 daN (kg)
Shipping weight	50925 lbs 23100 daN (kg)	50,704 lbs 23,000 daN (kg)	49,381 lbs 22,400 daN (kg)	48,941 lbs 22,200 daN (kg)
Operating weight, CE	54892 lbs 24900 daN (kg)	54,672 lbs 24,800 daN (kg)	53,349 lbs 24,200 daN (kg)	52,908 lbs 24,000 daN (kg)
Track units				
Tracks, front	63" x 10" x 22"	63" x 10" x 22"	63" x 10" x 22"	63" x 10" x 22"
Tracks, rear	1,600 x 260 x 550 mm	1,600 x 260 x 550 mm	1,600 x 260 x 550 mm	1,600 x 260 x 550 mm
Tank capacities				
Fuel tank	224 gal 850 l	224 gal 850 l	224 gal 850 l	224 gal 850 l
Hydraulic oil tank	71 gal 270 l	71 gal 270 l	71 gal 270 l	71 gal 270 l
Water tank	422 gal 1,600 l	422 gal 1,600 l	422 gal 1,600 l	422 gal 1,600 l
Electrical system	24 V	24 V	24 V	24 V
Conveyor system				
Primary belt width	32" 800 mm	32" 800 mm	32" 800 mm	32" 800 mm
Discharge belt width	32" 800 mm	32" 800 mm	32" 800 mm	32" 800 mm
Belt capacity	379 yd ³ /h 290 m ³ /h	379 yd ³ /h 290 m ³ /h	379 yd ³ /h 290 m ³ /h	379 yd ³ /h 290 m ³ /h
Shipping dimensions				
Maschine L x W x H	21'9" x 8'6" x 9'4" 6,650 x 2,600 x 2,850 mm	21'9" x 8'2" x 9'4" 6,650 x 2,500 x 2,850 mm	21'9" x 7'9" x 9'4" 6,650 x 2,350 x 2,850 mm	21'9" x 7'9" x 9'4" 6,650 x 2,350 x 2,850 mm
Conveyor L x W x H	26'3" x 3'9" x 5' 8,000 x 1,150 x 1,500 mm	26'3" x 3'9" x 5' 8,000 x 1,150 x 1,500 mm	26'3" x 3'9" x 5' 8,000 x 1,150 x 1,500 mm	26'3" x 3'9" x 5' 8,000 x 1,150 x 1,500 mm

Dimensions in American standard and mm

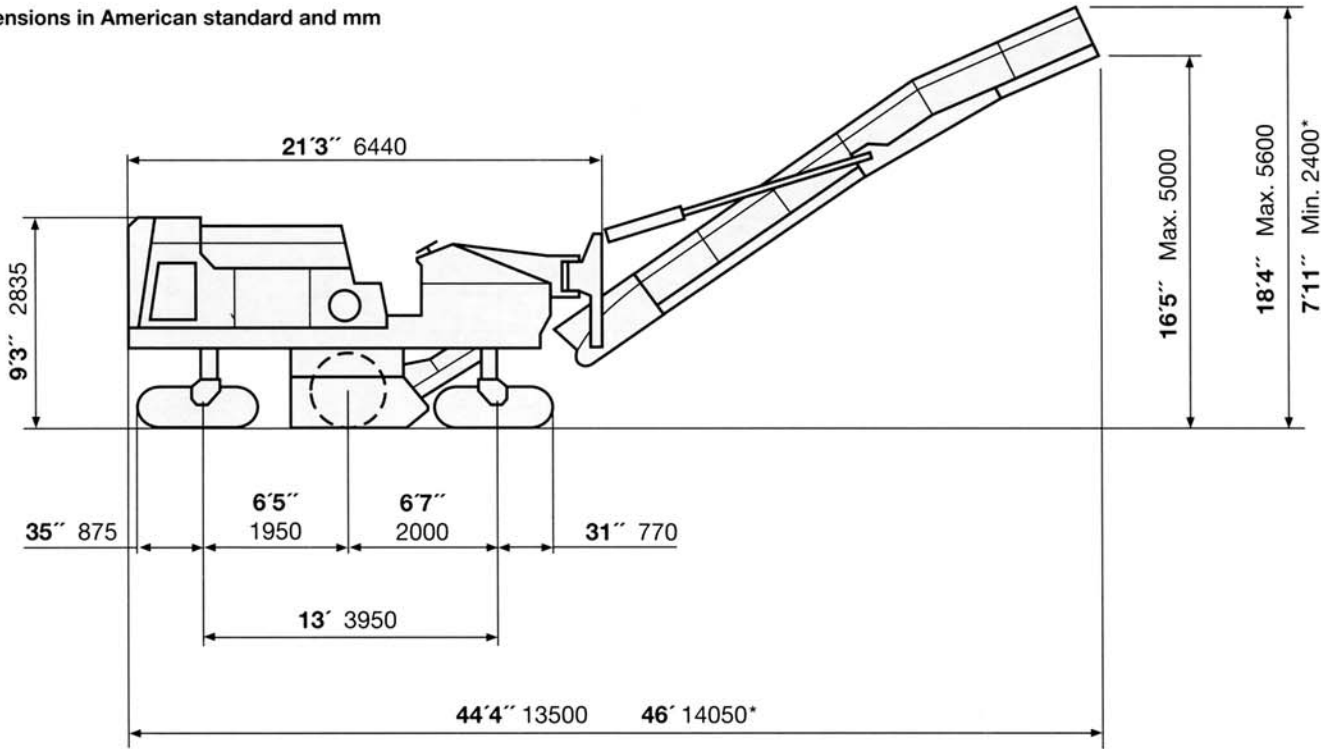

1500 DC · 1300 DC

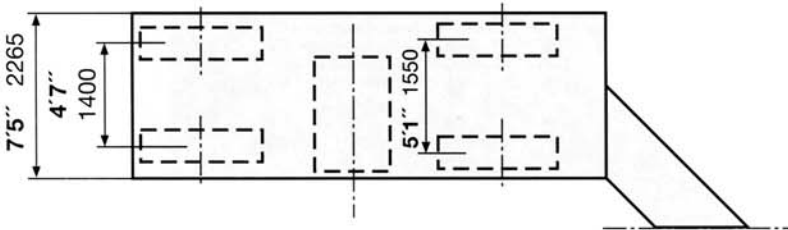

2000 DC · 1900 DC

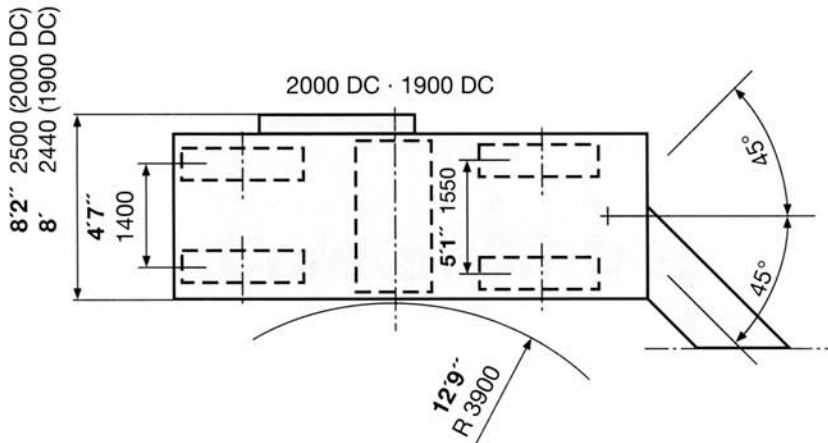

* = Flat-bed trailer transportation dimensions

Optional: Folding discharge conveyor

Dimension in American standard and mm

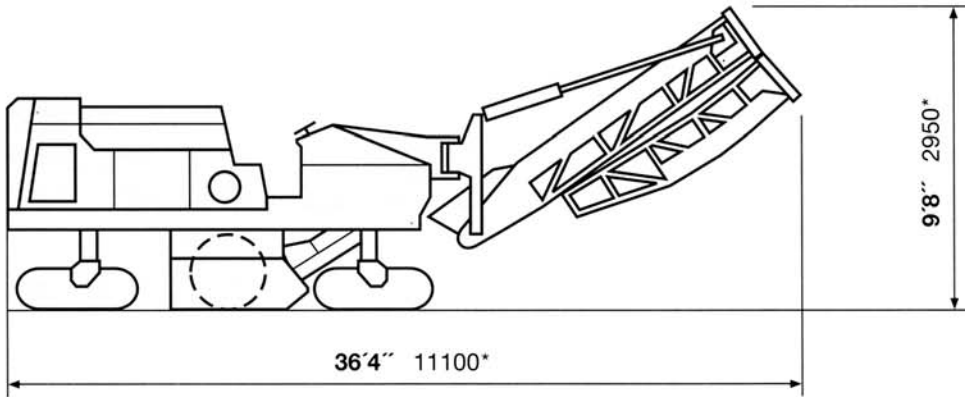
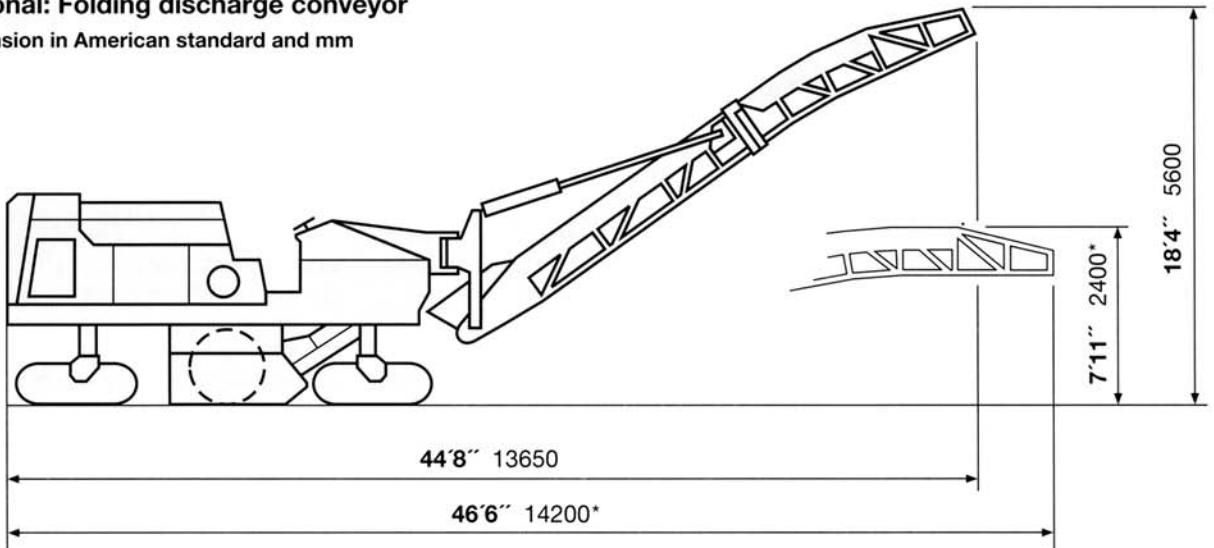

* = Low-loader transportation dimensions

Optional: Additional water tank and canopy with screen

Dimensions in American standard and mm

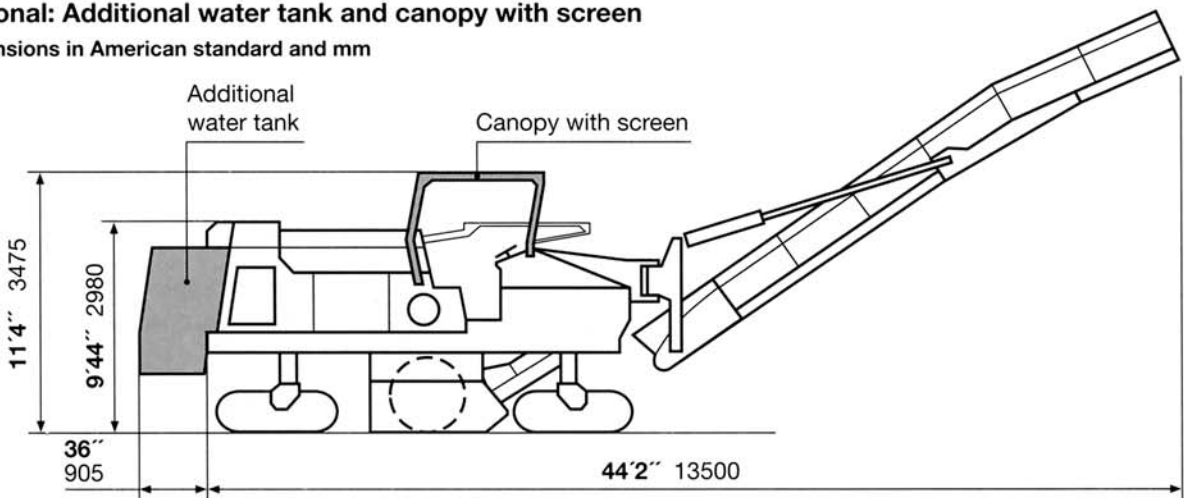

Basic design

Road milling machine with mechanically driven milling drum and two-part front loading conveyor which can be slewed and adjusted in height. Crawler tracks are installed as standard equipment.

Chassis

Robust welded structure with mounts for the individual units and superstructures, as well as integrated tanks for diesel fuel, hydraulic fluid and water. The individual components are optimally arranged to ensure easy access for maintenance and service.

Track suspension

All four track units are mounted on the chassis on hydraulically operated telescopic guides which can be individually adjusted in height. The milling depth is set by adjusting the telescopic guides at the front. The rear telescopic guides are used to raise and lower the machine for operation and travel. The tracks are equipped as standard with thermo-plastic track pads.

Steering

The machine is equipped with a soft-running hydraulic four-track dual steering system (on right and left of walk-through operator's platform).

Travel drive system

All four tracks are individually driven by independent hydraulic motors which are fed by a common hydraulic variable displacement pump. Speeds in milling gear and travel gear are infinitely variable from zero to maximum speed. A selectable differential lock ensures uniform traction.

Automatic power control

The machine is equipped with automatic power control which adjusts the feed in accordance with the load on the diesel engine. The automatic power control can be overridden for manual operation.

Brakes

Braking is achieved by drag from the hydrostatic transmission. The road milling machine is additionally

equipped with automatic disc parking brakes.

Milling drum

The drum operates in an up-milling direction. Toolholders accommodating the round-shank cutters are welded onto the drum. Special edge flighting ensures a clean cut at the edges. Additional ejectors ensure that the RAP is transferred cleanly to the loading conveyor.

Tool changes

The scraper blade opens hydraulically to permit easy access to the milling drum for tool changes.

Drum drive

The milling drum is driven mechanically by the diesel engine and the power transmitted via a clutch and power bands to the drum gearing. The power bands are tensioned automatically via a hydraulic cylinder.

Milling depth control

The milling machine is equipped with an electronic depth control system. The reference level is sensed at the drum side plates or on the existing carriageway surface. The electronic depth control system ensures that the set values are maintained by correcting the position of the depth adjustment cylinders. Slope control is also available as an optional extra and simply plugs into sockets, installed as standard equipment.

Water spray system

The formation of dust clouds during the milling process is largely prevented by a water spray system, thus also reducing the amount of wear on the cutters. The spray nozzles can be removed without difficulty for cleaning.

Soundproofing

Soundproofing is fitted as standard equipment to reduce the amount of noise generated and to protect both the operator and the environment from excessive noise.

Operator's platform

The walk-through operator's platform is located in the middle of the

machine and is equipped with two consoles, one on the right and one on the left. The driver's ergonomically designed seat, the low height and the good visibility help to facilitate the machine's operation. The modern operating and control elements are located within easy reach and within the driver's view.

Instrumentation

Operating hours counter, tank indicator, rev counter, engine temperature indicator, battery charging indicator, pressure gauges for control pressure, belt pressure and track drive pressure, filter contamination warning indicator.

Hydraulic system

Separate hydraulic systems for travel drive, loading conveyors, cooler fan, water sprinkler unit and control functions. The hydrostatic pumps are driven by the diesel engine via a splitter gearbox. Filtration is effected via return flow and feed pressure filters, as well as via pressure filters for the control functions.

Conveyor system

The integrated conveyor system comprises a wide primary conveyor which picks up the RAP at the milling drum and a discharge conveyor for loading the RAP onto trucks. The discharge conveyor can be adjusted in height and slewed to both sides. Both conveyor belts are ribbed. The discharge conveyor is covered to prevent the formation of dust clouds in windy weather.

Electrical system

24 V system with 3-phase alternator and two 12 V batteries, starter, socket outlet and horn, as well as the complete working and safety lights.

Filling systems

Water is filled via a standard C-type fitting or large filling port. Diesel is filled via large filling ports.

Safety during transport

The machine is equipped with sturdy lashing lugs for loading by crane or to secure it on a flat-bed trailer.

Wirtgen America Inc.
204 River Hills Drive
Nashville, Tennessee 37210
U. S. A.

Phone: (615) 391-0600
Fax: (615) 391-0791

Specification

○ Standard ● Optional

Specification	2000 DC	1900 DC	1500 DC	1300 DC
Working lights (removable)	○	○	○	○
Warning light	○	○	○	○
Complete tool kit	○	○	○	○
Loading and lashing eyes	○	○	○	○
Soundproofing	○	○	○	○
Walk-through operator's station	○	○	○	○
4-track dual steering	○	○	○	○
Loading conveyor system	○	○	○	○
Automatic grade control	○	○	○	○
Reversing alarm	○	○	○	○
German Safety Council approved (GS)	○	○	○	○
Comprehensive safety package with 5 Emergency OFF switches	○	○	○	○
Engine output 398 HP (297 kW)	○	○	○	○
Conveyor belt width 32" (800 mm)	○	○	○	○
Folding discharge conveyor	●	●	●	●
Variable discharge conveyor speed	●	●	●	●
Hydraulically lifting primary conveyor	●	●	●	●
Hydraulically freewheeling	●	●	●	●
Quick-change tool holder system	●	●	●	●
Air compressor	●	●	●	●
Pneumatic air tool for quick tool change	●	●	●	●
Operator station canopy with screen	●	●	●	●
Hydraulic side plate lifters	●	●	●	●
Additional valve to lock scraper blade	●	●	●	●
High-pressure water wash down	●	●	●	●
Extra multiple sensing system for longitudinal leveling	●	●	●	●
Slope control	●	●	●	●
Wire-rope sensor	●	●	●	●
Additional rear water filling pipe	●	●	●	●
Additional water tank 264 gal (1000 l)	●	●	●	●
Petrol-driven filling pump for water tank	●	●	●	●
Hydraulic filling pump for water tank	●	●	●	●
Filling pump for diesel tank	●	●	●	●
Special painting	●	●	●	●
Conveyor support legs for low-loader transport	●	●	●	●
Exchangeable milling drum with 67" (2,010 mm) working width	○	●	—	—
Exchangeable milling drum with 63" (1,905 mm) working width	●	○	—	—
Exchangeable milling drum with 5' (1,500 mm) working width	●	●	○	●
Exchangeable milling drum with 44" (1,320 mm) working width	●	●	●	○
Exchangeable milling drum with 40" (1,000 mm) working width	●	●	●	●
Cyclon air filter	●	●	●	●