

Cold milling machine W 600 DC

Technical specification



Technical specification

	Cold milling machine W 600 DC	
Milling width max.	24" 600 mm	
Milling depth*¹	0–12" 0–300 mm	
Milling drum		
Tool spacing	5/8" 15 mm	
Number of tools	68	
Drum diameter with tools	37" 930 mm	
Engine		
Manufacturer	Deutz	
Type	BF 6 M 1013 EC	
Cooling	Water	
Number of cylinders	6	
Output	129 kW/173 HP/175 PS	
Engine speed	2,300 min ⁻¹	
Displacement	436 in ³ 7,140 cm ³	
Fuel consumption, full load	9.1 gal/h 34.5 l/h	
Fuel consumption, 2/3 load	6.8 gal/h 25.6 l/h	
Speeds/Gradeability		
1 st milling gear	0–49 ft/min 0–15 m/min	
2 nd milling gear	0–98 ft/min 0–30 m/min	
Travel gear	0–4.7 mph 0–7.5 km/h acc. to German regulations: 5.9	
Theoretical gradeability, 1 st gear	89 %	
Theoretical gradeability, travel gear	15 %	
Transversal inclination, max.	10 °	
Ground clearance	13" 325 mm	
Weights*²	3 wheels	4 wheels
Front axle load, full tanks	9,921 lbs 4,500 daN (kg)	10,472 lbs 4,750 daN (kg)
Rear axle load, full tanks	17,306 lbs 7,850 daN (kg)	17,306 lbs 7,850 daN (kg)
Own weight	25,904 lbs 11,750 daN (kg)	26,455 lbs 12,000 daN (kg)
Operating weight, CE* ³	26,455 lbs 12,000 daN (kg)	27,073 lbs 12,280 daN (kg)
Operating weight, full tanks	27,227 lbs 12,350 daN (kg)	27,778 lbs 12,600 daN (kg)
Tyres		
Type of tyres	Solid rubber	Solid rubber
Tyre size, front (diameter x width)	22" x 12" 560 x 305 mm	22" x 9" 560 x 230 mm
Tyre size, rear (diameter x width)	22" x 10" 560 x 255 mm	22" x 10" 560 x 255 mm
Tank capacities		
Fuel tank	63 gal 240 l	
Hydraulic fluid tank	19 gal 70 l	
Water tank	112 gal 425 l	
Electrical system	24 V	
Conveyor system		
Belt width	16" 400 mm	
Theoretical conveyor capacity	87 yd ³ /h 67 m ³ /h	
Shipping dimensions/Weights*²		
Dimensions of machine (L x W x H)	15'5" x 6'5" x 8'4" 4,700 x 1,950 x 2,550 mm	
Dimensions of conveyor (L x W x H)	23'7" x 40" x 40" 7,200 x 1,000 x 1,000 mm	
Weight of machine	24,251 lbs 11,000 daN (kg)	24,802 lbs 11,250 daN (kg)
Weight of conveyor	1,874 lbs 850 daN (kg)	1,874 lbs 850 daN (kg)

*¹ = The maximum milling depth may deviate from the value indicated, due to tolerances and wear.

*² = All weights refer to basic machine without any additional equipment.

*³ = Weight of machine with half-full water tank, half-full fuel tank, driver (165.4 lbs / 75 kg) and tools.

Technical description

Dimensions in American standard and mm

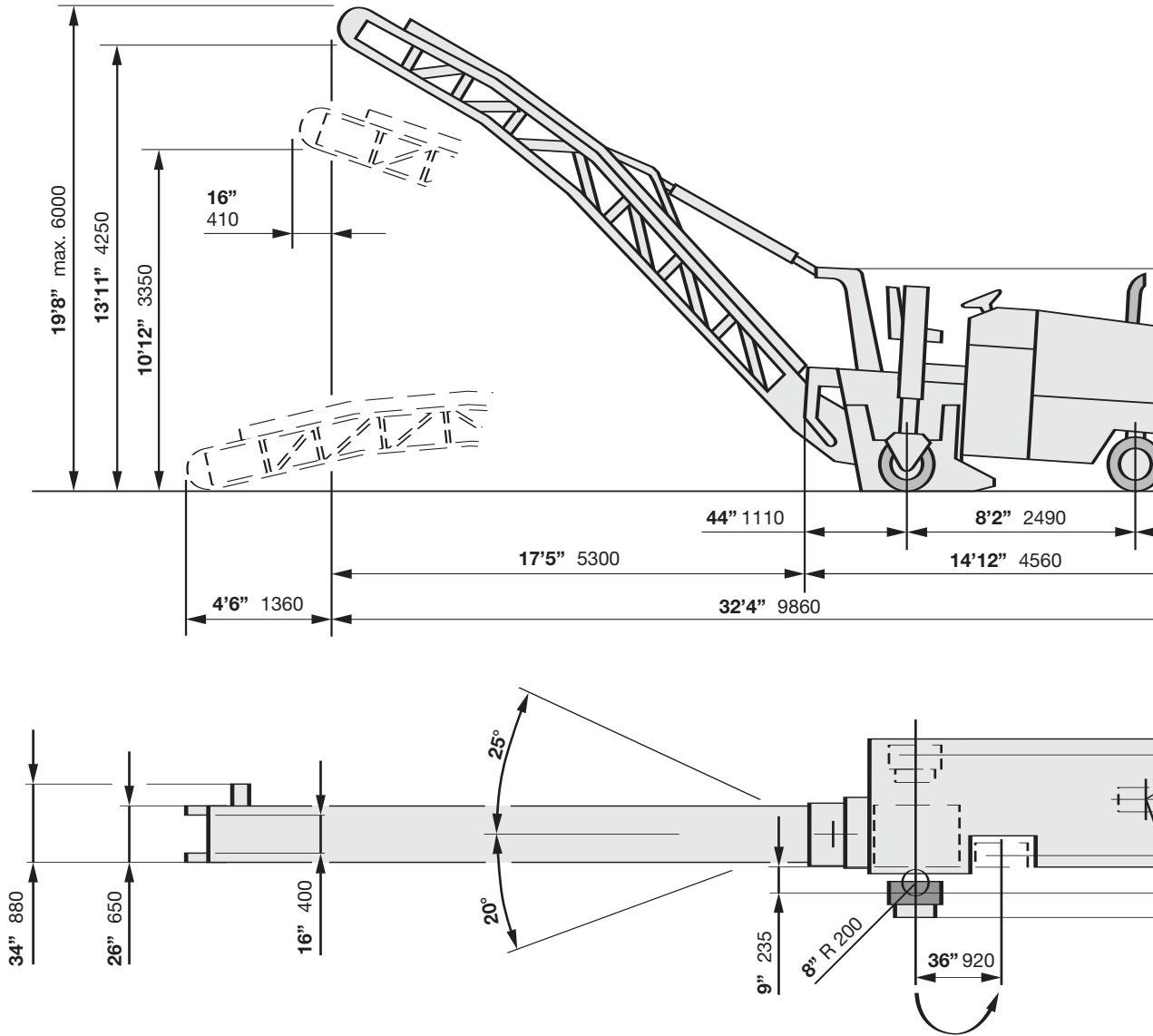

Basic design

The W 600 DC is a road milling machine with mechanically driven milling drum and conveyor system. The machine is equipped with permanent all-wheel drive as a standard feature.

Chassis

Robust welded construction with mounts for the individual function modules. The tanks for diesel fuel, hydraulic fluid and water are integrated into the chassis.

An optimum arrangement of the individual components ensures easy access for maintenance and servicing.

Operator's platform

The operator's platform is located at the rear of the machine. The comfortable sitting position combined with ergonomically arranged operating elements allows the driver to operate the machine without fatiguing and ensures a clear overview of the machine. The seat and steering

wheel can be individually adjusted to meet each operator's personal needs. The control elements are located within easy reach and within the driver's field of vision. The most commonly used controls are integrated into the armrest together with the advance drive lever.

Power unit

The machine is driven by a powerful six-cylinder diesel engine. An integrated cooling system and heavy-duty fan en-

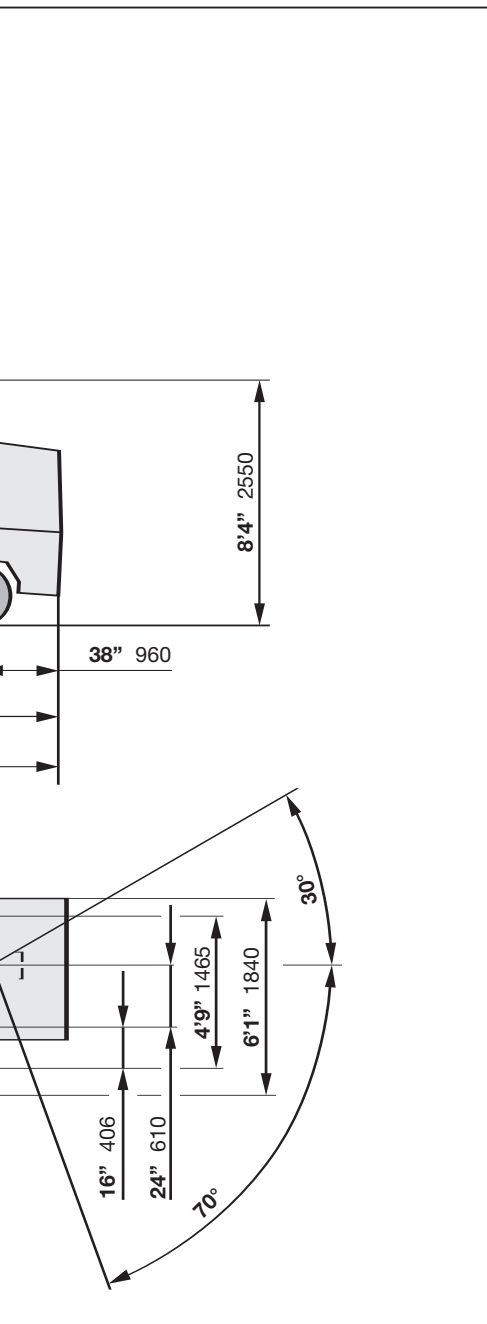

the operating personnel and the environment against any nuisance due to noise.

Milling drum drive

The milling drum is driven mechanically by the diesel engine via a mechanical clutch, angular transmission and power belts acting on the drum gearbox. The power belts ensure optimum transmission of the power, damp any impacts and protect the other units against overloading. Constant tension of the power belts is automatically maintained by a hydraulic cylinder.

Milling drum

The milling drum is located between the rear wheels and operates in up-milling direction. Toolholders accommodating the point-attack cutting tools are welded onto the drum body. An optimum arrangement of the cutting tools ensures the smooth operation of the machine. Special edge segments ensure a clean sharp cut at the edges.

As an option, the milling drum can be equipped with the patented and established quick-change toolholder system HT11. With this system, the bottom parts of the toolholders are welded onto the drum body and the upper parts secured to the bottom parts by retaining bolts to allow quick replacement, thus minimizing any downtimes.

Due to its special bearing system, the complete milling drum can be pulled out to the side. Drums with milling widths of 12" (300 mm), 16" (400 mm), 20" (500 mm) and 24" (600 mm) are available for various applications. Replacement of the drums is facilitated by a mounting device and drum carriage which are available as an equipment option. Other milling drums of various widths and shapes are available for special applications. Customized versions can be produced upon request.

Cutting tool replacement

The scraper blade opens hydraulically and the side plates can be locked in the upper position to permit easy access to the milling drum for the replacement of cutting tools. The power belts can be slackened manually so that the drum turns effortlessly, thus facilitating the tool replacement.

Drive unit

The machine is steered via the front wheel. The rear wheels are suspended

individually and designed as supporting wheels. The right-hand rear wheel can be manually swivelled in front of the milling drum to improve the side clearance, for instance when working along kerbs.

Travel drive

The cold milling machine W 600 DC has three (optionally four) separately driven wheels. The travel drive motors are fed by two common hydraulic variable displacement pumps.

The travel speed can be infinitely varied from zero to maximum speed in both milling gears and in travel gear. A hydraulic flow divider acts as differential gear ensuring uniform traction. The traction effort is uniformly distributed when the lock is activated and, briefly, also when reversing.

Steering

The machine has a finger-light hydraulic steering system. Extremely tight locking angles allow exceedingly small turning clearance circles.

Brake system

Braking is achieved by the self-locking hydrostatic transmission. The road milling machine is additionally equipped with an automatic spring-loaded braking system in the travel drive gearboxes of both rear wheels.

Loading the milled material

Clean loading of the milled material is ensured by means of a scraper blade. Carbide segments on the edges of the scraper blade ensure a long service life.

The scraper blade can be locked at the required height with variable contact pressure when milling right down to the gravel course. In addition, it can also be adjusted so that the milled trench can be refilled or part of the reclaimed material loaded on trucks.

The milled material is picked up by the integrated conveyor in the milling chamber and transferred to trucks via a wide conveyor system. By means of a special coupling device, the conveyor can be mounted and dismounted quickly without the driver having to leave the operator's platform for this purpose.

sure trouble-free operation even at high outside temperatures. The engine complies with the stringent requirements of the exhaust emission standards stipulated by the US Environmental Protection Agency (EPA, Tier II) and the EU (Stage II). All maintenance work can be carried out from one machine side.

Soundproofing

Noise levels are reduced by the standard soundproofing which also protects both

The loading conveyor can be adjusted in height and slewed to both sides. The material is transported reliably and safely by the V-ribbed belt.

The loading conveyor is covered to prevent clouds of dust being blown away by the wind and causing a nuisance.

Milling depth adjustment and automatic levelling system

The milling depth is set via the hydraulic height adjustment of the rear drive units. The drive units can be conveniently adjusted independently of one another from the driver's seat, where the set values can be monitored on separate height indicators, even with the supporting wheel swivelled in front of the drum. This feature permits the simple and accurate production of wedged cuts.

The automatic levelling system from Wirtgen can be installed as an equipment option. With this system, a reference plane is scanned, for example, by

a wire-rope sensor and the height adjusted automatically.

Hydraulic system

The hydraulic systems for travel drive, loading conveyor and setting functions are mutually independent. The hydraulic pumps are driven by the diesel engine via a power take-off, thus permitting a highly compact design. The oil in the system is cleaned by return-flow and suction filters. It is cooled by the hydraulic fluid cooler integrated at the diesel engine.

Electrical system

24 V electrical system with starter, 3-phase alternator and two 12 V/88 Ah batteries, as well as a socket outlet (24 V).

Water spray system

The formation of dust clouds during the milling operation is largely prevented by

an electrically operated water spray system which also cools the cutting tools, thus considerably extending their service life. The spray nozzles are easily removed for cleaning.

Filling

Water is filled via a C-pipe connection or a large filling port. Diesel fuel is filled via a large filling port.

Safety features

The cold milling machine can be securely lashed onto a low-bed trailer or loaded by crane (cross-beam) with the aid of the lashing lugs permanently attached to the machine. A powerful horn, easily accessible emergency stop button and extensive working and safety lights ensure that the machine can be operated safely, even in darkness or inclement weather.

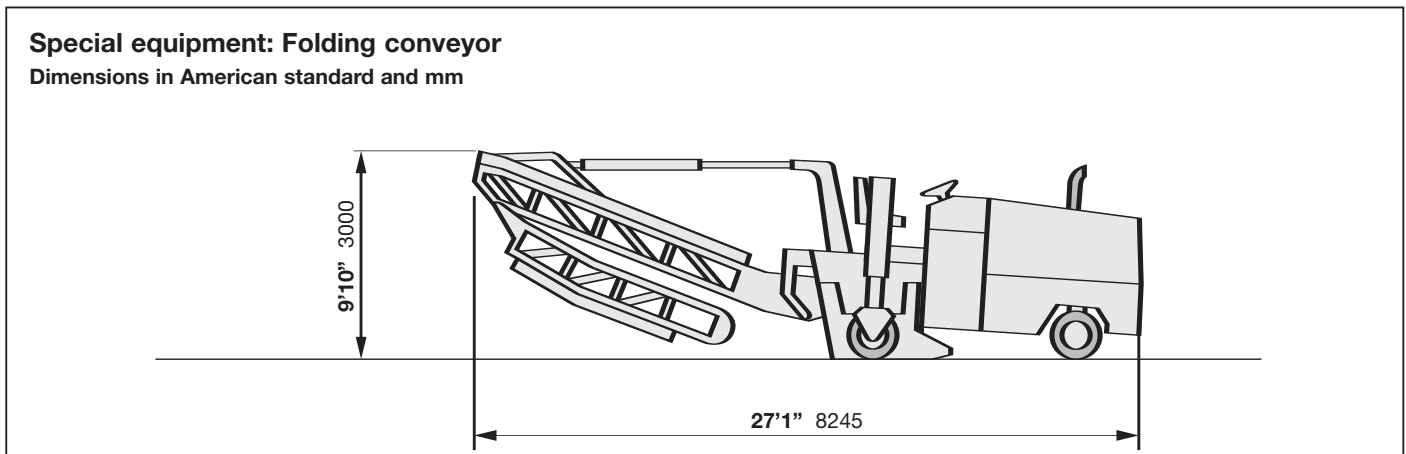
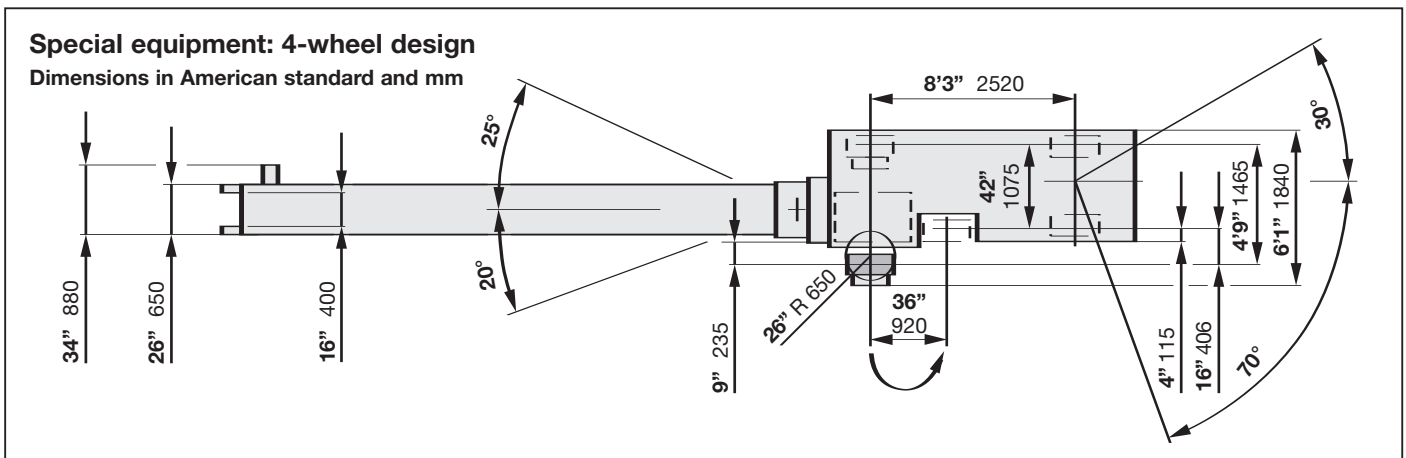

○ Standard ● Option

Equipment	Cold milling machine W 600 DC
Frame/Operator's platform	
Footwell heating	○
Canopy, manually retractable	●
Special painting	●
Transport	
Loading and lashing lugs	○
Towing device	○
Road traffic licence	●
Exterior rear view mirror, right	●
Machine control and levelling system	
Automatic levelling system with wire-rope sensor right/left	●
Automatic levelling system with slope control sensor	●
Drive unit/Wheels	
All-wheel drive and switchable differential lock	○
4-wheel design with front axle	●
Milling drum assembly	
Hydraulically lifting side plates	●
Milling drum with milling width 12" (300 mm), centrally positioned (milling depth 10" (250 mm))	●
Milling drum with milling width 16" (400 mm) (milling depth 12" (300 mm))	●
Milling drum with milling width 20" (500 mm) (milling depth 12" (300 mm))	●
Quick-change toolholder system HT11	●
Mounting device for milling drum replacement	●
Drum carriage for milling drum replacement	●
Loading the milled material	
Loading conveyor with quick-release coupling	○
Adjustable conveyor belt speed	○
Folding conveyor	●
Non-supply of conveyor system	●
Miscellaneous	
Comprehensive tool kit	○
Working lights	○
Warning beacon	○
Safety certificate by the Employer's Liability Insurance Association	○
Comprehensive safety package with emergency stop button	○
Reversing horn	○
Soundproofing	○
Hydraulic hammer	●
Hydraulic power take-off for ancillary equipment	●
Operation of the cold milling machine with organic hydraulic fluid	●



WIRTGEN AMERICA

Wirtgen America Inc.
6030 Dana Way
Nashville, TN 37013, USA

Phone: (615) 501-0600

Fax: (615) 501-0691

Internet: www.wirtgenamerica.com