



Technical specification

Cold Milling Machine W 250



Technical specification

| | | Cold milling machine W 250 |
|---|-------------|-----------------------------------|
| Milling width | | 2,200 mm |
| Milling depth *1 | | 350 mm |
| Milling drum | | |
| Tool spacing | | 15 mm |
| Number of tools | | 188 |
| Drum diameter with tools | | 1,140 mm |
| Engine | | |
| Manufacturer | | CUMMINS |
| Type | | QSX 15 + QSL 8.9 |
| Cooling | | Water |
| Number of cylinders | | 6 + 6 |
| Rated power at 2,000 min ⁻¹ | | 708 kW / 949 HP / 963 PS |
| Maximum power at 1,900 min ⁻¹ | | 731 kW / 980 HP / 994 PS |
| Operating power at 1,600 min ⁻¹ | | 659 kW / 884 HP / 896 PS |
| Displacement | | 23.9 l |
| Fuel consumption at rated power | | 197 l/h |
| Fuel consumption in field mix | | 78 l/h |
| Emission standards | | EC Stage 3a / US EPA Tier 3 |
| Electrical system | | 24 V |
| Tank capacities | | |
| Fuel tank | | 1,460 l |
| Hydraulic fluid tank | | 300 l |
| Water tank | | 4,850 l |
| Driving properties | | |
| Travel speed in milling and travel gear, max. | | 0–88 m/min |
| Crawler tracks | | |
| Crawler tracks front and rear (L x W x H) | | 2,100 x 370 x 750 mm |
| Loading of milled material | | |
| Belt width of primary conveyor | | 1,100 mm |
| Belt width of discharge conveyor | | 1,100 mm |
| Theoretical capacity of discharge conveyor | | 668 m ³ /h |
| Shipping dimensions | | |
| Machine | (L x W x H) | 10,300 x 2,840 x 3,000 mm |
| Discharge conveyor | (L x W x H) | 8,150 x 1,700 x 1,500 mm |

*1 = The maximum milling depth may deviate from the value indicated, due to tolerances and wear.

Dimensions in mm

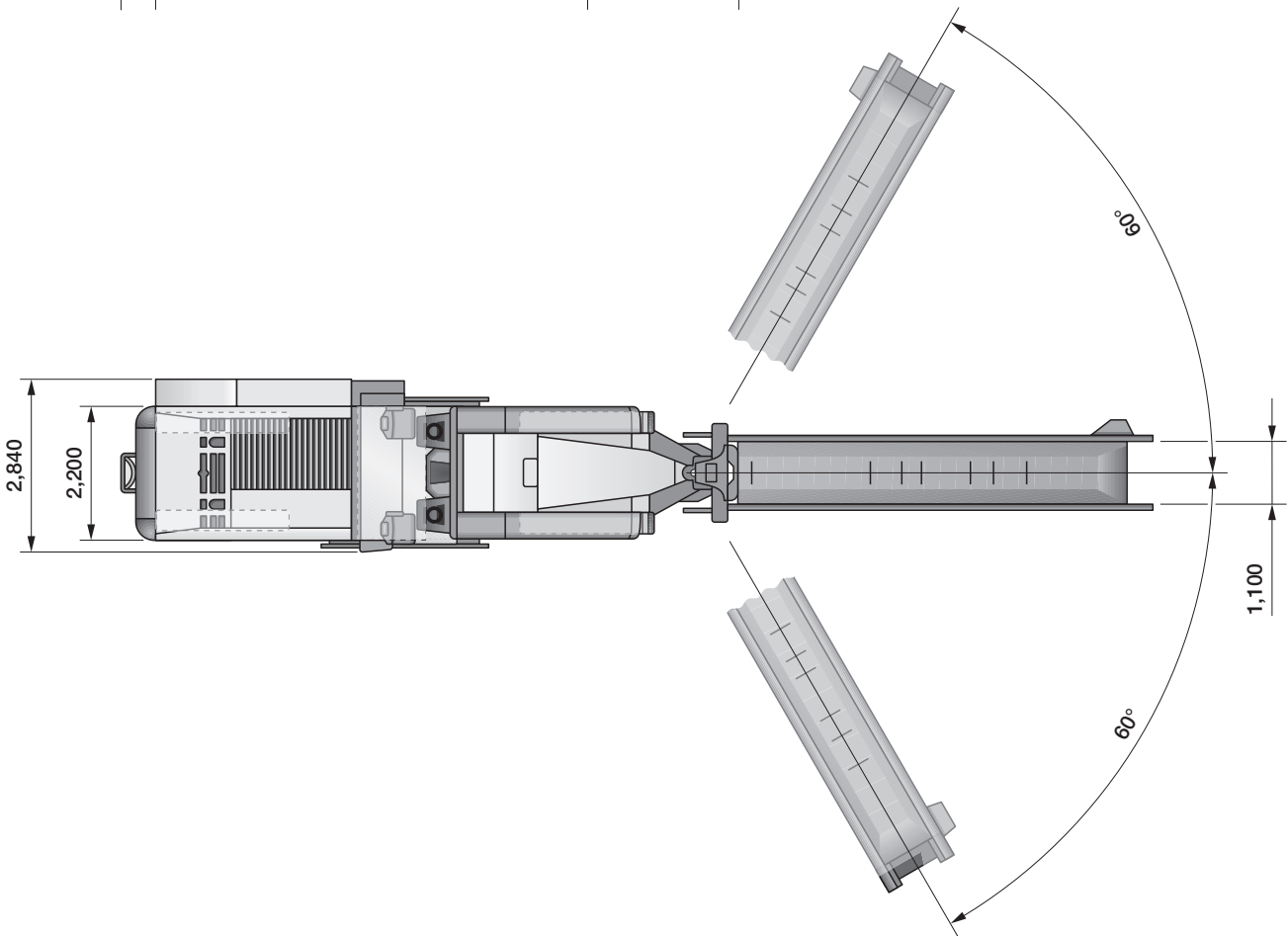
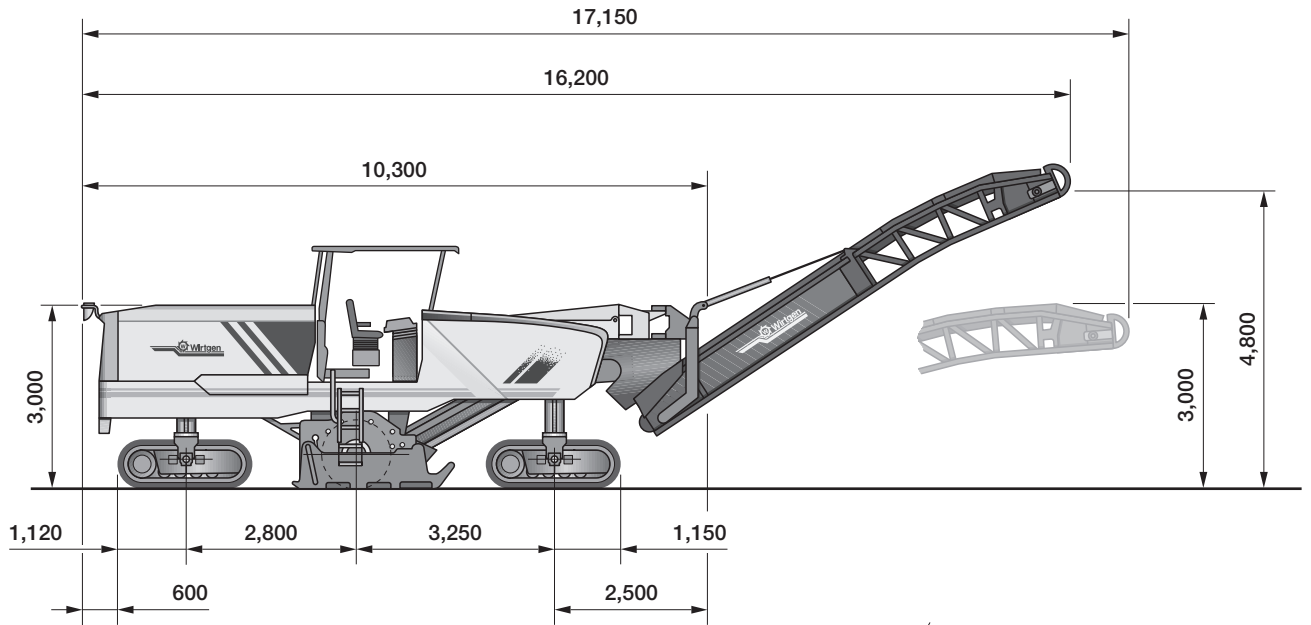

| Machine weights of cold milling machine W 250 | |
|--|-----------------|
| Empty weight of machine without filling media | 40,600 daN (kg) |
| Operating weight, CE * | 43,740 daN (kg) |
| Maximum operating weight (full tanks, full range of equipment), milling width 2,200 mm | 50,810 daN (kg) |
| Weights of filling media | |
| Water tank filling in kg | 4,850 daN (kg) |
| Diesel tank filling in kg (0.83 kg/l) | 1,212 daN (kg) |
| Optional equipment features increasing / reducing empty weight | |
| FCS Light milling drum assembly and milling drum, milling width 2,200 mm, milling depth 0-350 mm | 600 daN (kg) |
| FCS milling drum assembly and milling drum, milling width 2,500 mm, milling depth 0-350 mm | 1,700 daN (kg) |
| FCS milling drum assembly and milling drum, milling width 3,100 mm, milling depth 0-350 mm | 4,500 daN (kg) |
| FCS milling drum assembly and milling drum, milling width 3,500 mm, milling depth 0-350 mm | 6,650 daN (kg) |
| FCS milling drum assembly and milling drum, milling width 3,800 mm, milling depth 0-350 mm | 8,300 daN (kg) |
| FCS milling drum assembly and milling drum, milling width 4,400 mm, milling depth 0-350 mm | 11,600 daN (kg) |
| FCS Light milling drum, milling width 2,200 mm, HT11 and tool spacing 25 mm | -180 daN (kg) |
| FCS Light fine milling drum, milling width 2,200 mm, HT5 and tool spacing 6x2 mm | 780 daN (kg) |
| Canopy | 270 daN (kg) |
| Conveyor in folding conveyor design | 600 daN (kg) |
| Operator's platform with comfortable seats | 250 daN (kg) |
| VCS - Vacuum Cutting System | 150 daN (kg) |
| Supplementary weight for flexible use | 1,500 daN (kg) |

* = Weight of machine with half-full water tank, half-full fuel tank, driver (75 kg) and on-board tools.

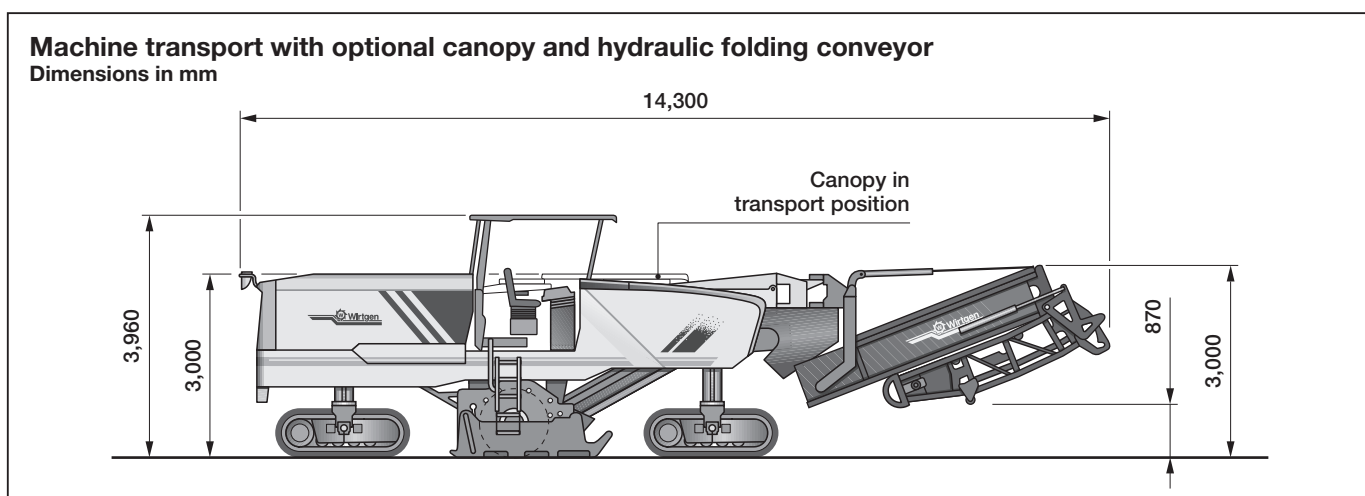

Rear view of W 250
Dimensions in mm

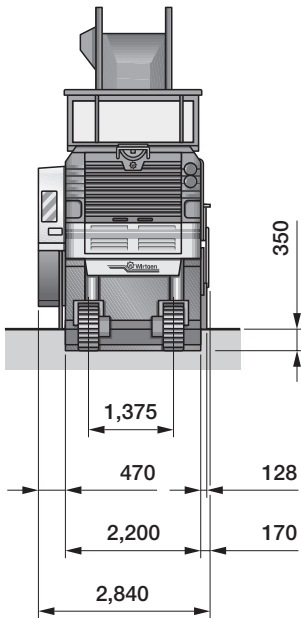

Milling width 2,200 mm

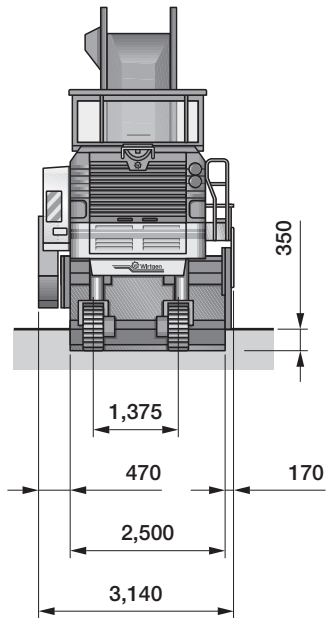

Milling width 2,500 mm

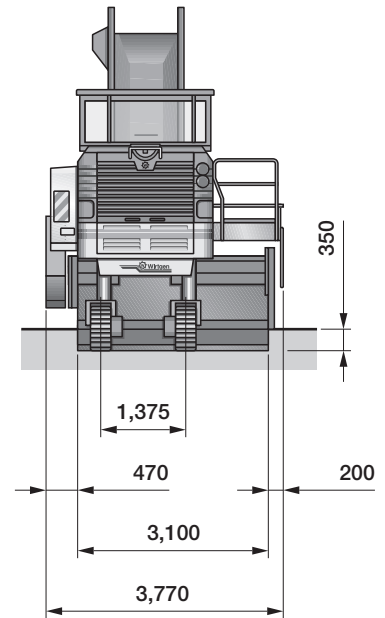

Milling width 3,100 mm

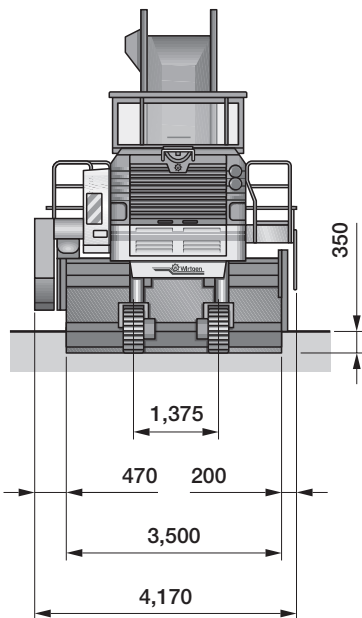

Milling width 3,500 mm

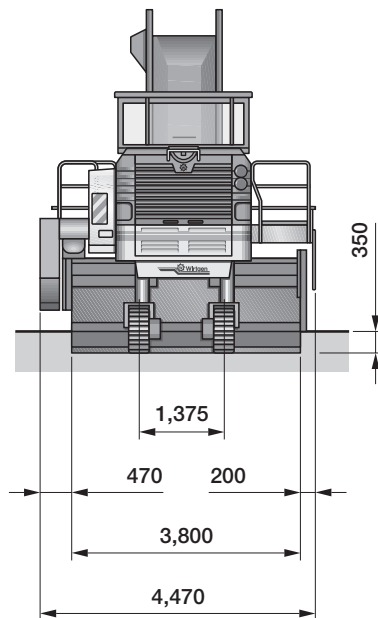

Milling width 3,800 mm

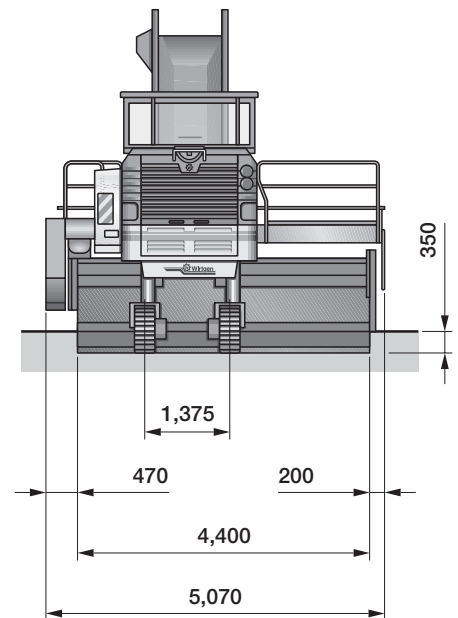

Milling width 4,400 mm

Milling radius of cold milling machine W 250, 150 mm milling depth
Dimensions in mm

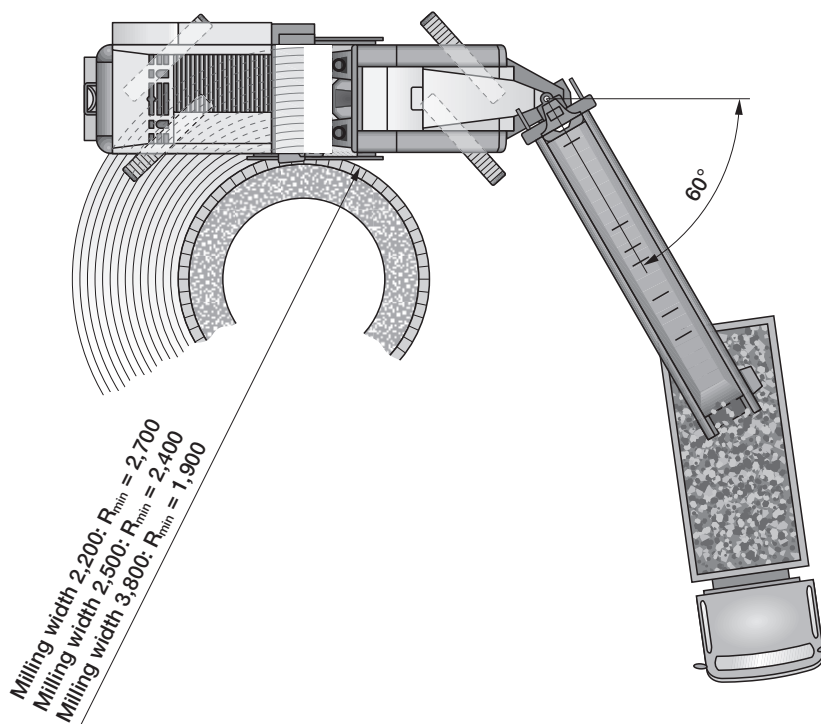
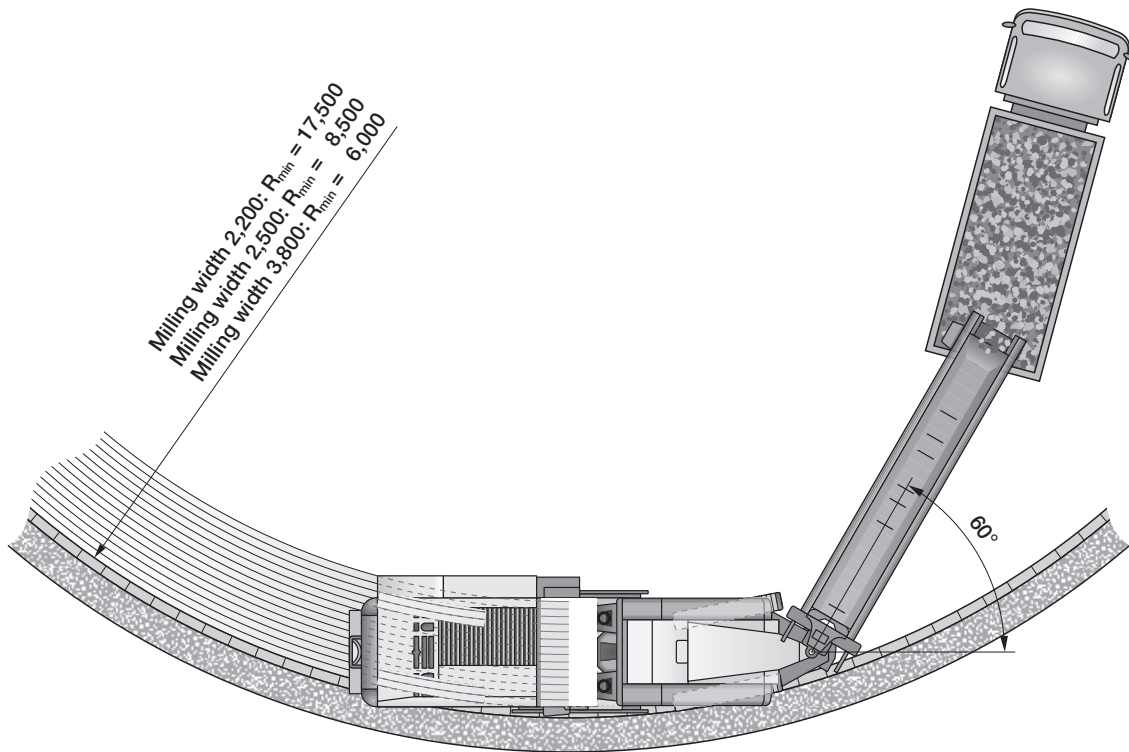

Equipment features of cold milling machine W 250

Standard equipment:

Basic machine with engine

- Machine frame in dual "wasp waist" design
- Hydraulically opening, soundproof engine cowling
- Engine cooling system with temperature-governed fan speed
- Air compressor system
- Automatically engaging high-pressure water system, 18 bar, 67 l/min
- Battery-operated hydraulic module for emergency functions
- Large storage compartments for cutting tool containers
- Standard painting in Wirtgen white with orange stripes

Milling drum housing

- Milling drum housing for milling width 2,200 mm without FCS features
- Three electrically switchable milling drum speeds 105 1/min - 94 1/min - 84 1/min
- Hydraulic gradation control beam with conveyor lift function
- Hydraulically movable and adjustable scraper blade with automatic locking function
- Hydraulically lifting edge protection plates, clearance right 450 mm, clearance left 350 mm
- Two separately engageable water spray bars in the milling drum assembly

Milling drums

- Milling drum, milling width 2,200 mm, HT11, tool spacing 15 mm
- Multiple-use ejector system

Loading of milled material

- Discharge conveyor without folding design
- Conveyor system with manually or automatically adjustable conveying speed
- Water spray system at primary conveyor
- Slewing angle of discharge conveyor $\pm 60^\circ$

Machine and levelling control

- Clearly structured main control panel with functional switches
- Multifunctional control screen with integrated display of major machine operation parameters
- Multifunctional truck loading indicator integrated in control screen
- Comprehensive machine diagnostics indicator integrated in control screen
- Automatically engaging milling power control unit
- Two exterior control panels for operation by ground staff
- Digital electric height indicator
- Pre-installation for up to 7 levelling sensors per machine side

Operator's platform

- Fully anti-vibration mounted operator's platform
- Convenient, individually adjustable control panel
- Convenient access to operator's platform, left and right
- Stand-up seat, left and right
- Lockable control panel covers
- Two mirrors at the front, two mirrors at the centre, one mirror at the rear of the machine

Chassis and height adjustment

- PTS - machine is automatically aligned parallel to the pavement surface
- ISC - intelligent track speed control with hydraulic four-track drive
- High machine stability through four-fold full-floating axle
- Four-track steering with freely selectable steering modes
- Extremely wear-resistant, two-piece EPS polyurethane track pads

Miscellaneous

- Lighting package with 14 halogen working spotlights
- Comprehensive toolkit in lockable toolbox
- Comprehensive safety package with 6 emergency stop switches
- European design type certification, GS mark (Geprüfte Sicherheit = Tested Safety) and CE conformity
- Warranty of 12 months or 1,000 engine operating hours
- Machine commissioning by qualified personnel

Optional equipment:

Basic machine with engine

- Operation of machine with biodegradable hydraulic fluid
- Special painting in one, two or several colours

Milling drum housing

- Milling drum housing for milling width 2,200 mm, FCS Light
- Milling drum housing for milling width 2,500 mm in FCS design
- Milling drum housing for milling width 3,100 mm in FCS design
- Milling drum housing for milling width 3,500 mm in FCS design
- Milling drum housing for milling width 3,800 mm in FCS design
- Milling drum housing for milling width 4,400 mm in FCS design
- Drum turning device for cutting tool replacement
- Pneumatic cutting tool driver and extractor
- Electro-hydraulically operated cutting tool extractor
- Fold-out additional seats at the rear crawler tracks for cutting tool replacement
- Mounting carriage for milling drum housing of 3,800 mm milling width

Milling drums

- FCS Light milling drum, milling width 2,200 mm, HT11, tool spacing 25 mm
- FCS Light fine milling drum, milling width 2,200 mm, HT5, tool spacing 6x2 mm
- Milling drum, milling width 2,500 mm, HT11, tool spacing 15 mm
- Milling drum, milling width 3,100 mm, HT11, tool spacing 15 mm
- Milling drum, milling width 3,500 mm, HT11, tool spacing 15 mm
- Milling drum, milling width 3,800 mm, HT11, tool spacing 15 mm
- Milling drum, milling width 4,400 mm, HT11, tool spacing 15 mm

Loading of milled material

- Hydraulically folding discharge conveyor
- VCS - Vacuum Cutting System
- Conveyor support legs for machine transport

Machine and levelling control

- LEVEL PRO automatic levelling system with hydraulic milling depth sensors at the edge protection plates, left and right
- Additional LEVEL PRO control panels
- Slope sensor
- Sensor for hydraulic scanning of the milling depth in front of the milling drum, right
- Sensor for hydraulic scanning of the milling depth in front of the milling drum, left and right
- Multiplex sensors with two additional ultrasonic sensors including bracket and cable in 3-fold Multiplex system package, right
- Multiplex sensors with two additional ultrasonic sensors including bracket and cable in 3-fold Multiplex system package, left and right
- Receiving sensor for level control by laser (excluding transmitter)
- Sonic ski sensor for scanning a stringline
- Pre-installation for 3D GPS levelling including receiver mast

Operator's platform

- Individually adjustable, comfortable driver's seats, left and right
- Operator's platform heating by conducting warm air into the footwell area
- "Stop-and-Go" indicator for trucks integrated in the partly electrically folding front mirrors
- Hydraulically retracting protective canopy

Miscellaneous

- Screen system including display
- Hydraulically operated electrical generator with a capacity of 4 kW at 220 volts
- Hydraulically operated electrical generator with a capacity of 4 kW at 110 volts
- Lighting balloon, 2.0 kW operated at 220 volts
- Lighting balloon, 2.0 kW operated at 110 volts
- Electrically operated diesel tank filling pump
- Hydraulically operated water tank filling pump
- Lighting package with 8 halogen and 6 Xenon spotlights
- Bolt-on supplementary weight, 1,500 kg
- Hydraulically operated high-pressure water cleaner, 150 bar, 15 l/min



Wirtgen GmbH
Reinhard-Wirtgen-Strasse 2 · 53578 Windhagen · Germany
Phone: +49 (0) 26 45/131-0 · Fax: +49 (0) 26 45/131-242
Internet: www.wirtgen.com · E-Mail: info@wirtgen.com